



See the possibilities

User's Manual

LQ-201CL

*RGB Color & NIR
4CMOS Line Scan Camera*

Document Version: 1.1
LQ-201CL_Ver.1.1_Dec2014

Notice

The material contained in this manual consists of information that is proprietary to JAI Ltd., Japan and may only be used by the purchasers of the product. JAI Ltd., Japan makes no warranty for the use of its product and assumes no responsibility for any errors which may appear or for damages resulting from the use of the information contained herein. JAI Ltd., Japan reserves the right to make changes without notice.

Company and product names mentioned in this manual are trademarks or registered trademarks of their respective owners.

Warranty

For information about the warranty, please contact your factory representative.

Certifications

CE compliance

As defined by the Directive 2004/108/EC of the European Parliament and of the Council, EMC (Electromagnetic compatibility), JAI Ltd., Japan declares that LQ-201CL complies with the following provisions applying to its standards.

CISPR Pub.22 (EN55022) (Emission admissible value and measuring method)

CISPR Pub.24 (EN55024) (Immunity admissible value and measuring method)

IEC61000-4-2(Electrostatic discharge immunity test)

FCC

This equipment has been tested and found to comply with the limits for a Class B digital device, pursuant to Part 15 of the FCC Rules. These limits are designed to provide reasonable protection against harmful interference in a residential installation. This equipment generates, uses and can radiate radio frequency energy and, if not installed and used in accordance with the instructions, may cause harmful interference to radio communications. However, there is no guarantee that interference will not occur in a particular installation. If this equipment does cause harmful interference to radio or television reception, which can be determined by turning the equipment off and on, the user is encouraged to try to correct the interference by one or more of the following measures:

- Reorient or relocate the receiving antenna.
- Increase the separation between the equipment and receiver.
- Connect the equipment into an outlet on a circuit different from that to which the receiver is connected.
- Consult the dealer or an experienced radio/TV technician for help.

Warning

Changes or modifications to this unit not expressly approved by the party responsible for FCC compliance could void the user's authority to operate the equipment.

Supplement

The following statement is related to the regulation on “ Measures for the Administration of the control of Pollution by Electronic Information Products “ , known as “ China RoHS “ . The table shows contained Hazardous Substances in this camera.

 mark shows that the environment-friendly use period of contained Hazardous Substances is 15 years.

重要注意事项

有毒，有害物质或元素名称及含量表

根据中华人民共和国信息产业部『电子信息产品污染控制管理办法』，本产品《有毒，有害物质或元素名称及含量表》如下。

部件名称	有毒有害物质或元素					
	铅 (Pb)	汞 (Hg)	镉 (Cd)	六价铬 (Cr(VI))	多溴联苯 (PPB)	多溴二苯醚 (PBDE)
棱镜	×	○	○	○	○	○
光学滤色镜	×	○	×	○	○	○
镜头座	×	○	○	○	○	○
连接插头	×	○	○	○	○	○
电路板	×	○	○	○	○	○
.....

○：表示该有毒有害物质在该部件所有均质材料中的含量均在SJ/T11363-2006规定的限量要求以下。
 ×：表示该有毒有害物质至少在该部件的某一均质材料中的含量超出SJ/T11363-2006规定的限量要求。
 (企业可在此处、根据实际情况对上表中打“×”的技术原因进行进一步说明。)



环保使用期限

电子信息产品中含有的有毒有害物质或元素在正常使用的条件下不会发生外泄或突变、电子信息产品用户使用该电子信息产品不会对环境造成严重污染或对基人身、财产造成严重损害的期限。

数字「15」为期限15年。

- Table of contents -

1.	General	6
2.	Camera composition	6
3.	Main features	7
4.	Locations and functions	8
4.1.	Locations and functions.....	8
4.2.	Rear Panel	9
5.	Connectors and pin assignment.....	10
5.1.	12-Pin Connector.....	10
5.1.1	Pin assignment	10
5.1.2	Conformable connector (Example).....	10
5.2.	Digital Output / Interface Connectors for Camera Link™	10
5.2.1	Pin assignment	10
5.2.2	Conformable connector and cable assembly	11
5.3.3	Camera Link Interface (Bit allocation)	11
5.3.4	Camera link output port	13
5.3.5	Bit allocation of the output video.....	14
6.	Functions and Operation.....	14
6.1.	Basic functions	14
6.2.	Key functions	15
6.2.1	Line rate (Command LR).....	16
6.2.2	Electronic shutter (Exposure) (Command PER, PEG, PEB, PEIR)	16
6.2.3	External Trigger.....	16
6.2.4	Serial communication	16
6.2.3	EEN (Exposure Enable) function	17
6.2.4	White balance	17
6.2.5	Gain control	18
6.2.6	Black level	19
6.2.7	PRNU (Pixel Response Non-Uniformity) correction	20
6.2.8	DSNU (Dark Signal Non-Uniformity) correction	21
6.2.10	Shading correction.....	21
6.2.11	Lateral chromatic aberration	23
6.2.12	Aperture filter.....	26
6.2.13	Binning	26
6.2.14	Sub-sampling	26
6.2.15	Windowing	27
6.2.16	Test pattern generator	27
6.3.	Operation modes.....	28
6.3.1	Camera Default Settings.....	28
6.3.2	No-Shutter mode with Internal Trigger	29
6.3.3	No-Shutter mode with external trigger	31
6.3.4	Shutter-Select mode with internal trigger.....	33
6.3.5	Shutter-Select mode with external trigger	36
6.3.6	Pulse Width Control (PWC) mode	38
6.3.7	Compatibility of trigger modes and functions.....	40
6.3.8	Trigger modes and auto white balance modes matrix table.....	40
7.	Functions listed alphabetically by command acronyms.....	41
7.1	Command AHRS - Request Status After One-Push AWB.....	41
7.2	Command AL - Automatic Line Rate Reference Level	41
7.3	Command AR - Automatic Line Rate Setting	41
7.4	Command ARST - Auto Reset Mode	41
7.5	Command AH - Activate One-Push Auto White Balance (AWB) - Shutter	43
7.6	Command AW - Activate One-Push Auto White Balance (AWB) - Gain.....	44
7.7	Command BA - Bit Allocation	44
7.8	Command BI - Binning	44

LQ-201CL

7.9	Command BL - Master Black Level	45
7.10	Commands BLR, BLB and BLIR - Black Level Red, Blue and NIR.....	45
7.11	Command BLM - Black Level Mode.....	45
7.12	Command CABR, CABB and CABIR Chromatic aberration Red, Blue NIR	45
7.13	Command EI - Interlocked R, G, B & NIR Exposure.....	45
7.14	Command GA - Master Gain Level	46
7.15	Commands GAR, GAB and GAIR - Gain Level Red, Blue and NIR.	46
7.16	Command GM - Gain Mode	46
7.17	Command HPFC - Aperture Control.....	46
7.18	Command LR - Line Rate (Scan Rate)	46
7.19	Command MAV - Chromatic Aberration Control	47
7.20	Command MAVCG - Chromatic Aberration Select	47
7.21.	Command NR - Noise Reduction.....	47
7.22	Command OS1,2,3,4,5,6 - Camera Link Video Output Select	47
7.22	Command PBC - Enable Pixel Black (FPN) Correction	47
7.23	Command PBR - Run Pixel Black Correction and Store to User Area	48
7.24	Command PBS - Request Status After Pixel Black Correction.....	48
7.25	Command PER,PEG,PEB and PEIR - Programmable Exposure for R,G,B,and NIR	48
7.26	Command PGC - Select pixel gain correction mode.....	48
7.27	Command PGR - Pixel Gain Correction and Store in User Area.....	49
7.28	Command PGS - Request Status After Pixel Gain Correction	49
7.29	Command SCB - Select cable	49
7.30	Command SDC - Select Shading Correction Mode.....	49
7.31	Command SDR - Run Shading Correction and store to user area.....	49
7.32	Command SDS - Request Status After Executing Shading Correction Command	50
7.33	Command SRO - Sensor Read Out.....	50
7.34	Command SGR, SGG, SGB, SGIR - Sensor Gain Set R, G, B and NIR.....	50
7.35	Command TG - Trigger Origin	50
7.36	Command TI - Trigger Input	50
7.37	Command TP - Trigger Polarity	50
7.38	Command TR - Trigger Mode	51
7.39	Command TS - Test Pattern	51
7.40	Command WB - White Balance	51
8.	Serial communication and command list.....	52
8.1.	Serial communication	52
8.2.	Command list	53
9.	Camera Control Tool for LQ-201CL.....	59
9.1.	Software Install	59
9.2.	Open the Control Tool	59
9.3.	Connect a camera	59
9.4.	Camera control window.....	60
9.5	Menus	60
9.5.1	File menu	60
9.5.2	Settings menu	60
9.5.3	Line Correction menu	61
9.5.4	Help menu	61
10.	External appearance and Dimensions	62
11.	Specifications	64
11.1	Typical data	64
11.2	Camera Spectral sensitivity.....	66
Appendix	67
1.	Precautions.....	67
2.	Typical Sensor Characteristics	67
3.	Caution when mounting a lens on the camera.....	67
4.	Caution when mounting the camera	68
5.	Exportation.....	68
6.	References	68



See the possibilities

Change history	69
User's Record	70

1. General

The LQ-201CL is a 4CMOS line scan camera using four 2048 pixel line sensors mounted on a prism, for the R, G, B and NIR channels. It operates with an 84 MHz pixel clock, resulting in a maximum line rate of 33,014 lines per second.

The camera outputs digital data in 4 x 8 bits or 4 x 10 bits format via Camera Link. The camera is configured by software through the serial communication port of the Camera Link interface, or via RS-232C through a 12-pin connector.

The camera accepts an M52 mount or F-mount lens, depending on the version selected.

The LQ-201CL is a suitable camera for various applications such as inspection of fruits, vegetables, circuits boards or electronic/mechanical parts, as the NIR image can catch scratches or blemishes on object surfaces which the RGB color image cannot find.

The latest version of the operation manual can be downloaded from www.jai.com.

The latest camera control tool for the LQ-201CL can be downloaded from www.jai.com.

For camera revision history, please contact your local JAI distributor

2. Camera composition

Two camera versions are available

LQ-201CL-M52	M52 mount
LQ-201CL-F	F mount

The standard camera composition is as follows.

Camera body	1
Sensor protection cap	1
Dear Customer (sheet)	1

The following optional accessories are available.

Power supply unit	PD-12 series
-------------------	--------------

3. Main features

- 4CMOS line scan camera with 2048 pixel resolution
- Dichroic beam splitter prism to separate R,G,B and NIR wavelengths
- 33,014 lines per second scan rate
- 84 MHz pixel clock
- 4 x 8 bits or 4 x 10 bits output through Camera Link interface
- PRNU and DSNU Flat-field correction
- Individual gain control in the range of -4dB to +14dB with a fine gain control
- Flat shading correction and color shading compensation
- One-push auto white balance using gain control or shutter control
- Binning function to increase sensitivity
- Sub-sampling and windowing functions for faster line rate
- Auto reset function
- Noise reduction function
- Test pattern generator(color bar, gray, white) for setup and trouble shooting
- Electronic shutter (for selected modes)
- Short ASCII commands set up via RS 232C or Camera Link
- M52 mount and F mount versions
- Field upgrade function by using exclusive update tool

4. Locations and functions

4.1. Locations and functions

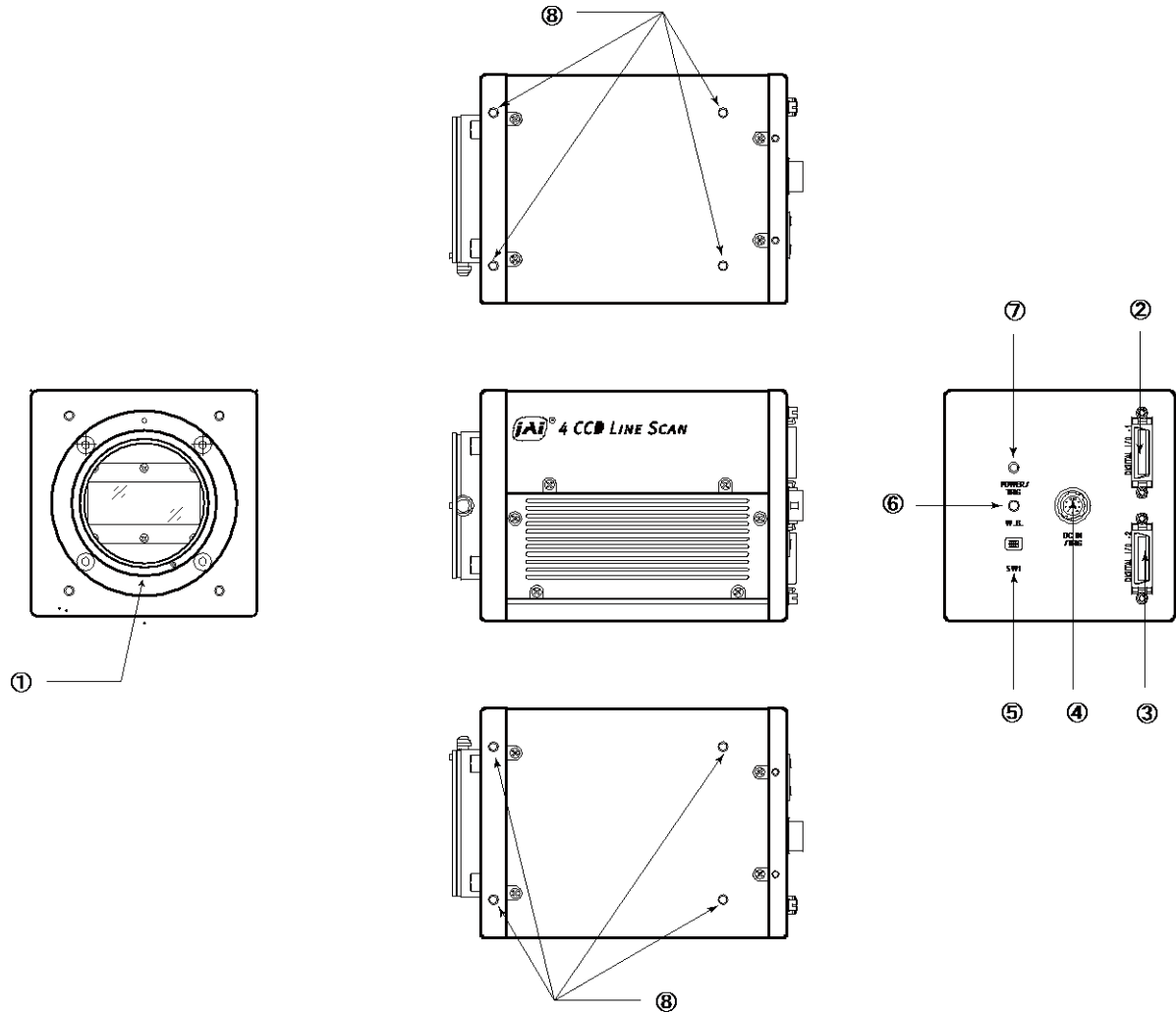

Fig. 1 Location of external features

- | | | |
|---|-------------------------|--|
| 1 | Lens mount | M52 mount (*1)Note) |
| 2 | Camera Link connector 1 | base connector (1) (*2)Note) |
| 3 | Camera Link connector 2 | medium connector (2) (*2)Note) |
| 4 | 12-pin Hirose connector | DC +12, External trigger and RS-232C |
| 5 | DIP switch | SW-1 (refer to chapter 4.2 for the details) |
| 6 | Button | For one-push auto white balance (Gain based) |
| 7 | LED indicator | Power, trigger input and operation indications |
| 8 | Camera mounting holes | 8 x M3, depth 5mm (*3) Note) |

*1) Note: Rear protrusion on M52 mount lens must be less than 13mm.

F mount is also available. Rear protrusion for F mount lens is the same as M52 mount.

*2) Note: When a Camera Link™ cable is connected to the camera, please do not excessively tighten screws by using a driver. The Camera Link receptacle on the camera might be damaged. For security, the strength to tighten screws is less than 0.291 Newton meter (Nm). Tightening by hand is sufficient in order to achieve this.

*3) Note: The depth of mounting hole is 5 mm. If the longer screws than 5 mm are used, they may damage the circuit board inside.

4.2. Rear Panel

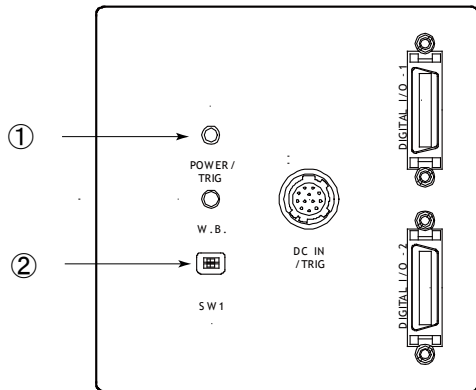

Fig2. Rear panel

① LED

● Green (Steady)

Operating, but not receiving external trigger input

*** Green (Flashing)**

Operating and receiving external trigger input.

Note that the flashing frequency does not correspond to the frequency of the trigger signal. The flashing does not occur in the No-shutter internal and Shutter-Select internal modes.

● Orange

Initializing and cannot operate

1) Initializing for approx. 800 ms

2) One-push auto white balance is engaged.

② DIP switch

SW-1 function

No	Function	Settings	
		ON	OFF
1	Serial communication	12-Pin	Camera Link (CC1)
2	Termination of External trigger	75 Ω	TTL

Note: Factory default settings for both functions are “OFF”.

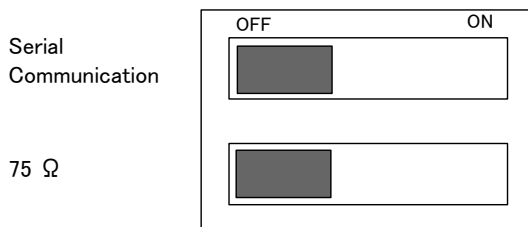

Fig.3 DIP switch

5. Connectors and pin assignment

5.1. 12-Pin Connector

5.1.1 Pin assignment

Type: HR10A-10R-12PB-01 (Male) or equivalent

Use the part number HR10A-10P-12S or equivalent for the cable side

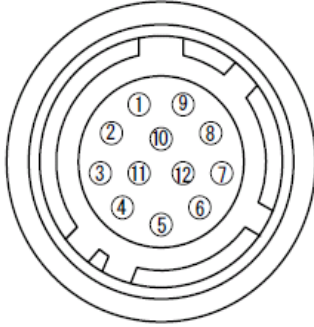

Pin No.	Signal	Remarks
1	GND	
2	DC in	+12V to +24V
3	GND	
4	Reserved	Do not connect
5	GND	
6	RxD in	RS-232C
7	TxD out	RS-232C
8	GND	
9	XEEN out	
10	Trigger in	
11	DC in	+12V to +24V
12	GND	

Fig. 4 12-pin Hirose connector

5.1.2 Conformable connector (Example)

No.	Manufacture	Type name	Note
Camera side	HIROSE	HR10A-10R-12PB(71)	
Cable side	HIROSE	HR-10A-10P-12S	Plug

5.2. Digital Output / Interface Connectors for Camera Link™

5.2.1 Pin assignment

Type: 26P MRD Connector 3M 10226-1A10PL

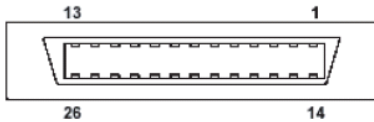

Fig. 5 Camera Link connector

This camera can be used with all Camera Link products that comply with the AIA Camera Link standard. Cables, transmission systems and frame grabbers/acquisition boards that do not comply with the Camera Link standard may work with this camera, but JAI Camera Solutions cannot be held responsible for loss in performance or damage of equipment, including the camera.

Connector 1 (4 x 8-Bit, 4 x 10-Bit)

Pin No	In/Out	Name	Note
1,14		Shield	GND
2(-),15(+)	O	TxOUT0	Data out
3(-),16(+)	O	TxOUT1	
4(-),17(+)	O	TxOUT2	
5(-),18(+)	O	TxClock	Clock for CL
6(-),19(+)	O	TxOUT3	Data out
7(+),20(-)	I	SerTC (RxD)	LVDS Serial Control
8(-),21(+)	O	SerTFG (TxD)	
9(-),22(+)	I	CC1 (Trigger)	Trigger
10(+),23(-)	I	CC2 (Reserved)	
11,24		N.C	
12,25		N.C	
13,26		Shield	GND

Connector 2 (Used only for 4 x 10-Bit output)

Pin No	In/Out	Name	Note
1,14		Shield	GND
2(-),15(+)	0	TxOUT0	Data out
3(-),16(+)	0	TxOUT1	
4(-),17(+)	0	TxOUT2	
5(-),18(+)	0	TxClock	Clock for CL
6(-),19(+)	0	TxOUT3	Data out
7(+),20(-)		N.C	
8(-),21(+)		N.C	
9(-),22(+)		N.C	
10(+),23(-)		N.C	
11,24		N.C	
12,25		N.C	
13,26		Shield	GND

5.2.2 Conformable connector and cable assembly

No.	Manufacture	Type name	Note
Camera side	3M	10226-1A10PL	
Cable assembly	3M	14B26-SZLB-xxx-0LC	Standard

Note1: In the above table, xxx shows cable length. Applicable length is 0.5m to 10m.

Note2: If the used cable does not comply with Camera Link standards or it is 14B26-SZ3B-xxx-03C (Thin diameter type) or 14B26-SZ3B-xxx-04C (High flex type), the cable length for transmission is limited.

5.3.3 Camera Link Interface (Bit allocation)

The LQ-201CL follows the Camera Link standard in all respects.

Out1_D9~Out1_D0 : Out1_Camera Data (Out1_D9=MSB, Out1_D0=LSB)

Out2_D9~Out2_D0 : Out2_Camera Data (Out2_D9=MSB, Out2_D0=LSB)

Out3_D9~Out3_D0 : Out3_Camera Data (Out3_D9=MSB, Out3_D0=LSB)

Out4_D9~Out3_D0 : Out4_Camera Data (Out4_D9=MSB, Out4_D0=LSB)

Out5_D7 ~Out3_D0 : Out5_Camera Data (Out5_D7=MSB, Out5_D0=LSB)

Out6_D7 ~Out3_D0 : Out6_Camera Data (Out6_D7=MSB, Out6_D0=LSB)

× : Don't Care

Port/Signal	8-bitx6output	10-bitx4output	Connector	Pin Name
Port A0	Out1_D0	Out1_D0	1	Tx0
Port A1	Out1_D1	Out1_D1	1	Tx1
Port A2	Out1_D2	Out1_D2	1	Tx2
Port A3	Out1_D3	Out1_D3	1	Tx3
Port A4	Out1_D4	Out1_D4	1	Tx4
Port A5	Out1_D5	Out1_D5	1	Tx6
Port A6	Out1_D6	Out1_D6	1	Tx27
Port A7	Out1_D7	Out1_D7	1	Tx5
Port B0	Out2_D0	Out1_D8	1	Tx7
Port B1	Out2_D1	Out1_D9	1	Tx8
Port B2	Out2_D2	×	1	Tx9
Port B3	Out2_D3	×	1	Tx12
Port B4	Out2_D4	Out2_D8	1	Tx13

LQ-201CL

Port B5	Out2_D5	Out2_D9	1	Tx14
Port B6	Out2_D6	×	1	Tx10
Port B7	Out2_D7	×	1	Tx11
Port C0	Out3_D0	Out2_D0	1	Tx15
Port C1	Out3_D1	Out2_D1	1	Tx18
Port C2	Out3_D2	Out2_D2	1	Tx19
Port C3	Out3_D3	Out2_D3	1	Tx20
Port C4	Out3_D4	Out2_D4	1	Tx21
Port C5	Out3_D5	Out2_D5	1	Tx22
Port C6	Out3_D6	Out2_D6	1	Tx16
Port C7	Out3_D7	Out2_D7	1	Tx17
Port D0	Out4_D0	Out4_D0	2	Tx0
Port D1	Out4_D1	Out4_D1	2	Tx1
Port D2	Out4_D2	Out4_D2	2	Tx2
Port D3	Out4_D3	Out4_D3	2	Tx3
Port D4	Out4_D4	Out4_D4	2	Tx4
Port D5	Out4_D5	Out4_D5	2	Tx6
Port D6	Out4_D6	Out4_D6	2	Tx27
Port D7	Out4_D7	Out4_D7	2	Tx5
Port E0	Out5_D0	Out3_D0	2	Tx7
Port E1	Out5_D1	Out3_D1	2	Tx8
Port E2	Out5_D2	Out3_D2	2	Tx9
Port E3	Out5_D3	Out3_D3	2	Tx12
Port E4	Out5_D4	Out3_D4	2	Tx13
Port E5	Out5_D5	Out3_D5	2	Tx14
Port E6	Out5_D6	Out3_D6	2	Tx10
Port E7	Out5_D7	Out3_D7	2	Tx11
Port F0	Out6_D0	Out3_D8	2	Tx15
Port F1	Out6_D1	Out3_D9	2	Tx18
Port F2	Out6_D2	×	2	Tx19
Port F3	Out6_D3	×	2	Tx20
Port F4	Out6_D4	Out4_D8	2	Tx21
Port F5	Out6_D5	Out4_D9	2	Tx22
Port F6	Out6_D6	×	2	Tx16
Port F7	Out6_D7	×	2	Tx17
LVAL 1			1	Tx24
FVAL 1			1	Tx25
LVAL 2			2	Tx24
FVAL 2			2	Tx25
DVAL			1	Tx26
EEN			1	Tx23

Note: LVAL 1, LVAL 2 and FVAL 1, FVAL 2 will show the same signal

(Output timing)

LQ-201CL

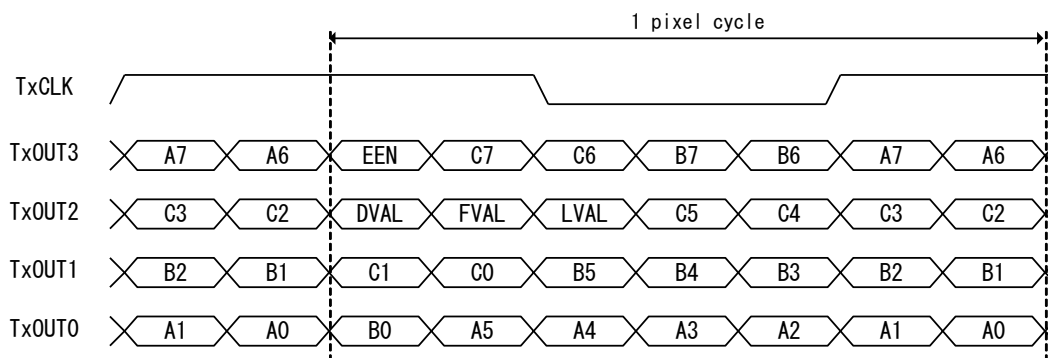
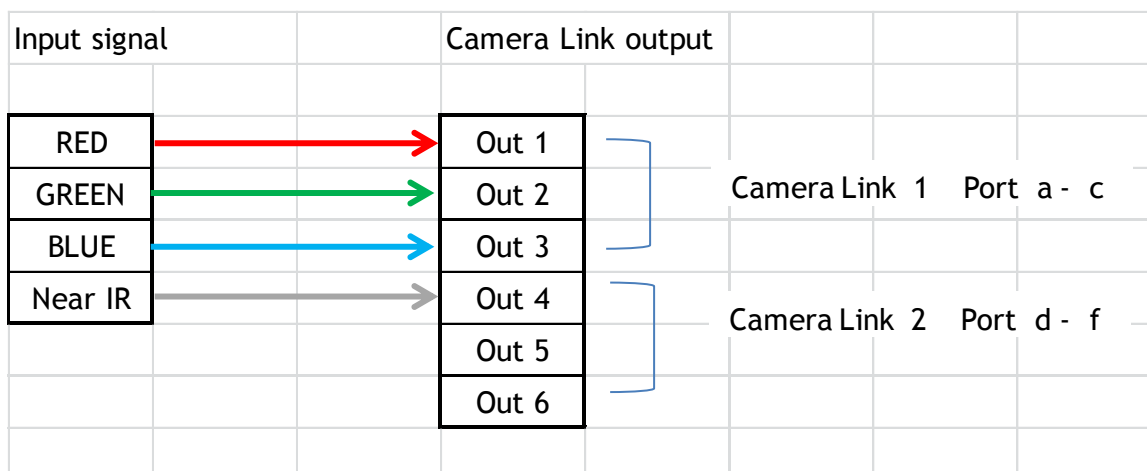

Fig.6 Camera Link output timing

5.3.4 Camera link output port

LQ-201CL handles R, G, B and NIR channels. The output ports for 8-bit and 10-bit are different.

8-bit output



10-bit output

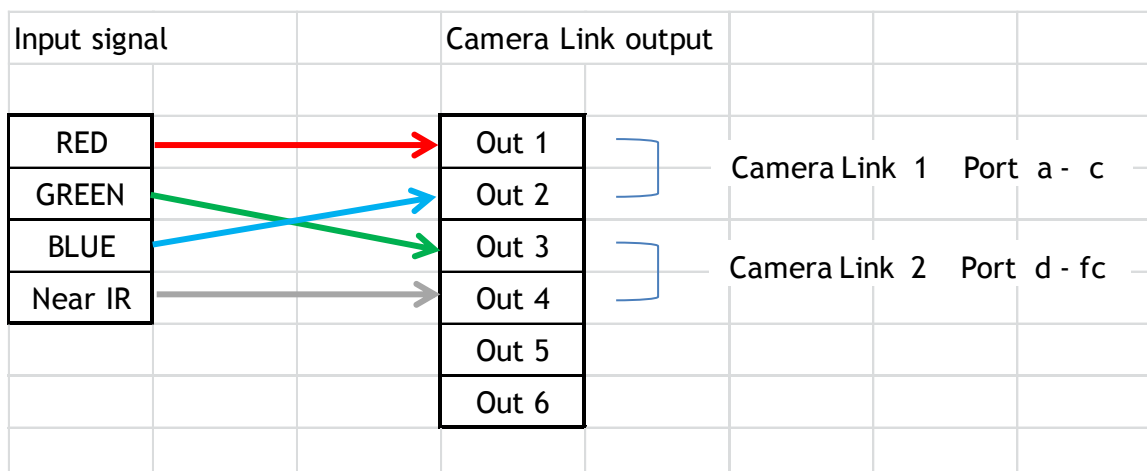

Fig. 7 Camera Link output configuration (Default)

5.3.5 Bit allocation of the output video

CMOS out	Digital 8-Bit (LSB)	Digital 10-Bit (LSB)
Black	8	32
200mV	222	890
230mV	255	1023

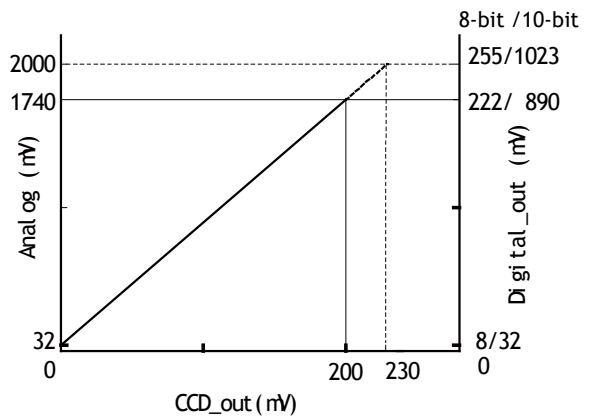

Fig.8 Video output

6. Functions and Operation

6.1. Basic functions

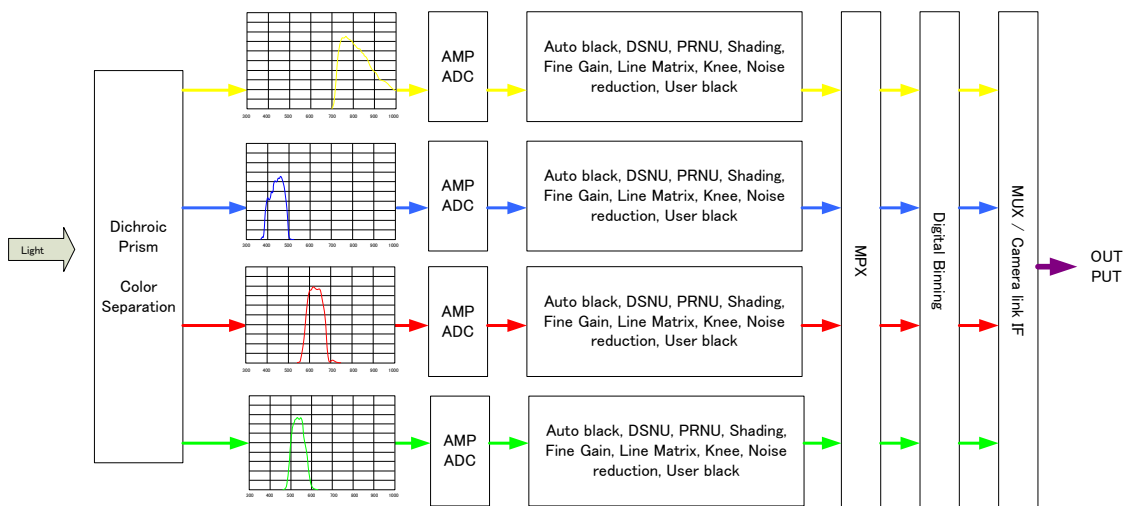
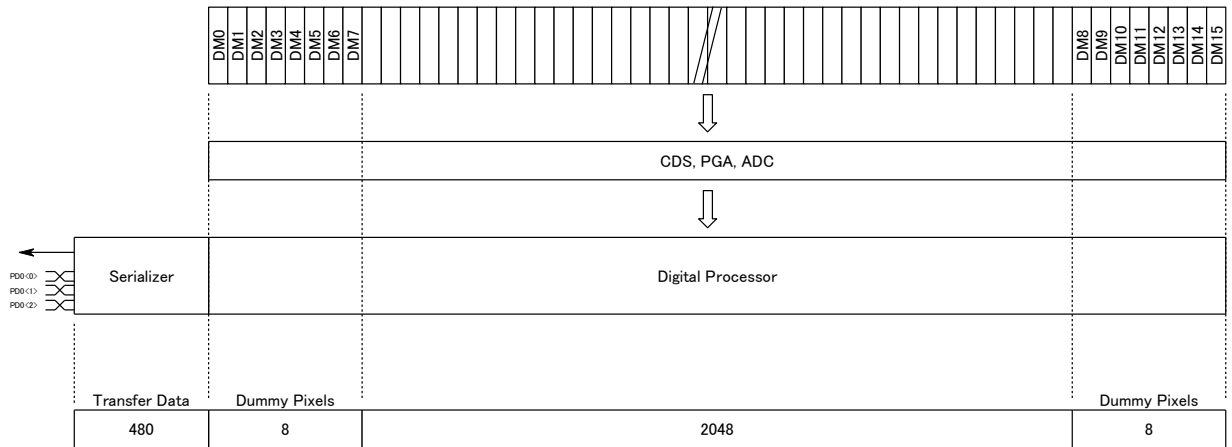

Fig.9 Signals flow

The LQ-201CL uses four high-performance CMOS line scan image sensors mounted on a prism block. During exposure, the incoming light is converted to electrons (electric charge) in the photodiodes (active pixels). The transfer gate controls the transfer of charge from photodiodes to the shift register. Activating the transfer gate terminates the exposure cycle, transfers the charge to the Horizontal Shift Register (2-phase buried channel CMOS shift register) and starts a new exposure cycle. The line is subsequently read out in a single sequence starting with pixel 1. The exposure time is normally the same as the cycle time (in No-shutter mode). By using the Exposure Control Gate (in Shutter-Select or Pulse Width Control trigger modes) the exposure time can be individually set to be shorter than the cycle time (the inverse of line rate). This also allows a fixed exposure time, independent of the line rate. In the LQ-201CL the exposure time can be set individually for all four channels.

LQ-201CL



DM : Dummy Pixels

Fig.10 Sensor layout

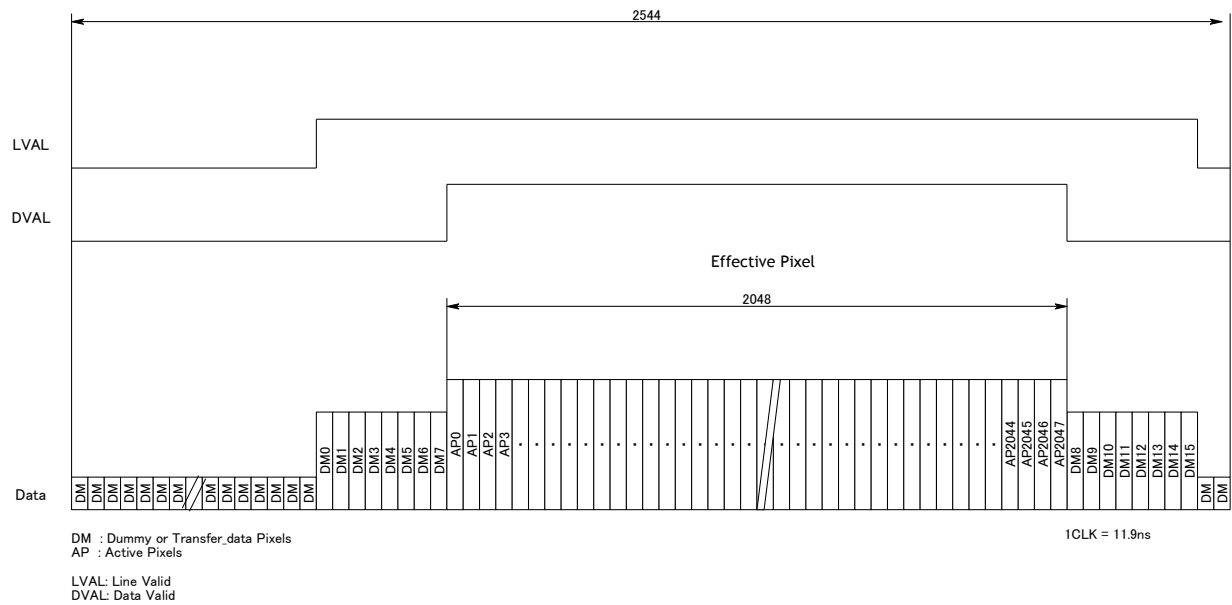

Fig.11 Video output timing

6.2 Key functions

Important note:

LQ-201CL has many functions explained in this chapter. In order to use these functions properly and to get proper image, please follow the procedure described below.

Setting procedure:

1. Set the shutter and line rate
2. Set the master gain (refer to the chapter 6.3.5 for the details)
3. Set the white balance (refer to the chapter 6.3.4 for the details)
4. Activate DSNU compensation (refer to the chapter 6.3.9 for the details)
5. Activate PRNU compensation (refer to the chapter 6.3.8 for the details)
6. Activate the shading compensation (refer to the chapter 6.3.10 for the details)

After completing the above, adjust black level, lateral chromatic aberration and knee adjustments. For these adjustments, there is no specific order required.

6.2.1 Line rate (Command LR)

This function can set the line rate longer than 1L. Accordingly, it is possible to set the camera scan rate with the object running speed or to boost up the sensitivity by setting longer exposure time.

- ♦ Adjusting range: 30.29 μ s(1L) to 15.0 ms
- ♦ Adjusting unit: 11.9 ns
- ♦ Operation mode: No Shutter/Internal Trigger and Shutter Select/Internal Trigger

The line rate can be automatically configured (one-push auto line set) (Command:AR). This function will calculate and set the line rate of the camera based on the Automatic Line Rate Reference Level (Command :AL) and the scene illumination. This function is available on No Shutter/Internal Trigger and Shutter Select/Internal Trigger modes.

6.2.2 Electronic shutter (Exposure) (Command PER, PEG, PEB, PEIR)

This function sets the exposure time regardless of line rate setting. The exposure time can be set for red, blue, green, and NIR, respectively.

Command PER, PEG, PEB and PEIR

- Adjusting range: 9.52 μ s to 14.99 ms (RGB and NIR individually)
- ♦ Adjusting unit: 11.9 ns (1clock) (RGB and NIR individually)
- ♦ Operation mode: Shutter Select/Internal Trigger and Shutter Select/External Trigger

Note: Upper limit of operable line rate

On Shutter Select/internal trigger mode

The line rate setting is the maximum line rate for operation

On Shutter Select/external trigger mode:

The trigger interval is the maximum value.

6.2.3 External Trigger

The external trigger can be input through the 12-pin connector or Camera Link CC1.

These cannot be used at the same time.

The external trigger signal can be terminated by 75 ohms inside the camera (Refer to Chapter 4.2).

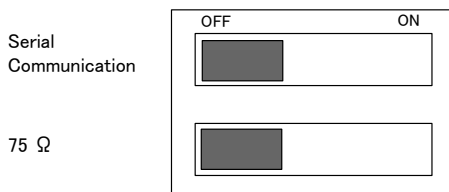

6.2.4 Serial communication

The camera can communicate by serial interface through the 12-pin or Camera Link interface. The default baud rate is 9600 bps. The serial interface of the 12-pin or Camera Link interface cannot be used at the same time. The selection of the communication interface can be done via the DIP switch located on the rear panel. (Refer to Chapter 4.2)

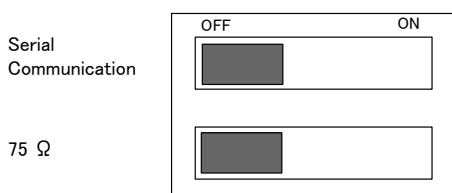

6.2.3 EEN (Exposure Enable) function

This function outputs the timing for image accumulation in all operating modes except test pattern output. The output can be through both the 12-pin and Camera Link connectors. The polarity of this output is negative from the 12-pin connector and positive from the Camera Link connector. These polarities cannot be changed. The following drawing shows the output through Camera Link.

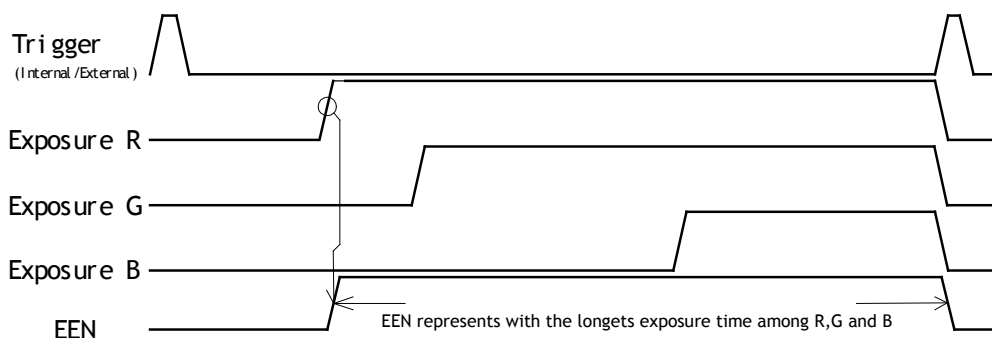

Fig.12 EEN function

6.2.4 White balance

In this function, the green channel video level is used as the reference. Red and blue channel levels are adjusted to match with that of the green channel.

There are two ways to adjust white balance: one is gain white balance and the other is shutter white balance.

White balance	Control tool	Command		Rear panel switch
		WB	AH	
Gain	○	○	×	○
Shutter	○	×	○	×

Gain white balance

Calculates the difference between green and red video levels, and green and blue levels, and adjusts the red and blue channels' video level so that the video level of all three channels becomes equal.

Command	WB=0	Manual/One push AWB
	WB=1	4000K
	WB=2	4600K
	WB=3	5600K

Shutter white balance (only for Shutter Select mode)

Calculates the difference between green and red video levels, and green and blue levels, and adjusts the red and blue channels' shutter speed so that the video level of all three channels becomes equal.

Command	AH=0	Activate one-push shutter AWB
---------	------	-------------------------------

Note:

If gain and shutter white balance are used in the External Trigger mode, external trigger pulses should be continuously provided while white balance adjustment is executing.

6.2.5 Gain control

The LQ-400CL has two ways of setting gain - one for master mode and the other for individual mode. Each setting also has two analog gain modes - one is GAIN LOW and the other is GAIN HIGH. Gain Low is the default output setting. The following shows the setting procedures and adjustable range.

1. Master mode (Default setting)

Gain Low mode:

- ◆ Reference value: 0dB
- ◆ Master gain control range : 0dB to 8dB
- ◆ R,B and NIR adjusting range :-4dB to +6dB (at the master gain setting value)

Gain High mode:

- ◆ Reference value: +6dB
- ◆ Master gain control range : 0dB to 8dB
- ◆ R, B and NIR adjusting range :-4dB to +6dB (at the master gain setting value)

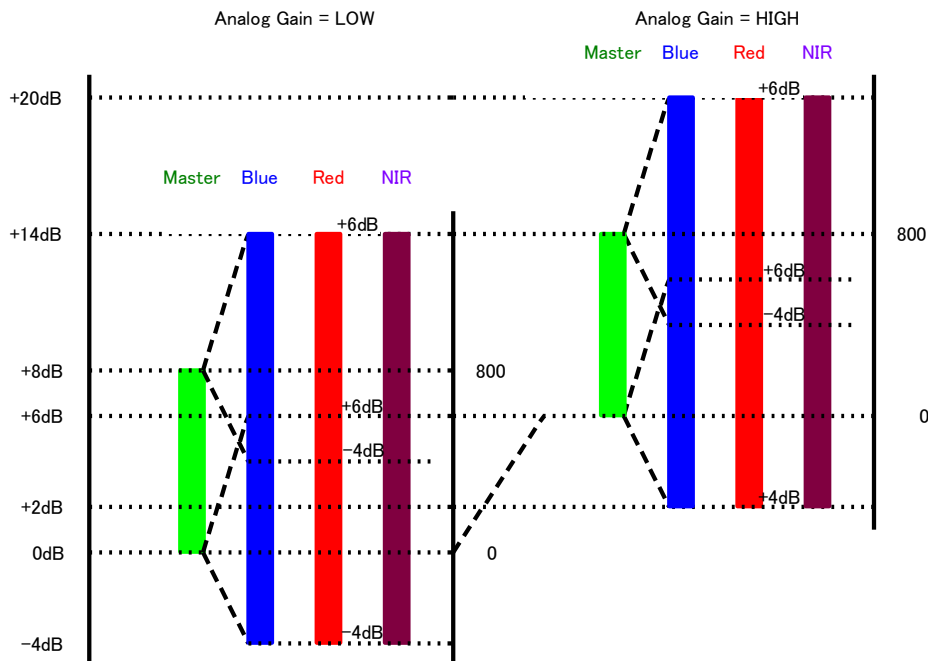

Fig.13 Master gain mode with Gain Low and High

2. Individual gain mode

Gain Low mode:

- ◆ Reference value: 0dB
- ◆ R, G, B and NIR adjusting range :-4dB to +14dB (at the master gain setting value)

Gain High mode:

- ◆ Reference value: +6dB
- ◆ R, G, B and NIR adjusting range :-4dB to +14dB (at the master gain setting value)

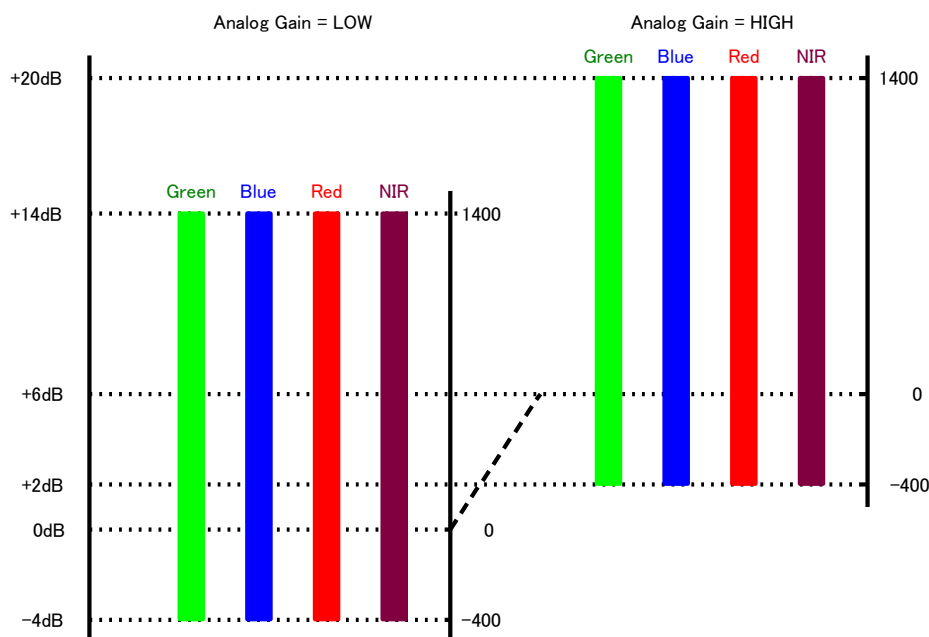

Fig.14 Individual gain mode with gain low and gain high

6.2.6 Black level

The setup level of the LQ-400CL is set at 8LSB in 4 x 8-bit output mode as the factory default setting (32LSB for 4 x 10-bit output mode)

In order to adjust, the following commands are available.

BLM= 0 Master mode
 BLM= 1 Individual mode
 BL= 0 to 64
 BLR= -64 to 63
 BLB= -64 to 63
 BLIR= -64 to 63

If the gain is set at Master mode:

- ♦ Adjusting range Master(green) : 0LSB to 64LSB (16LSB)
 Red : -64(-16) LSB to +64(16) LSB
 Blue : -64(-16) LSB to +64(16) LSB
 NIR : -64(-16) LSB to +64(16) LSB
 Figures in () are for 8-bit output

If the gain is set at Individual mode:

- ♦ Adjusting range Red : 0LSB to 64(16) LSB
 Green : 0LSB to 64(16) LSB
 Blue : 0LSB to 64(16) LSB
 NIR : 0LSB to 64(16) LSB
 Figures in () are for 8-bit output
 Note: Red, green, blue and NIR can be adjusted individually

6.2.7 PRNU (Pixel Response Non-Uniformity) correction

PRNU (Pixel Response Non-Uniformity) is, as the name implies, a non-uniformity of the response of each individual pixel. This means that for a fixed light level each pixel will have a slightly different output level (response).

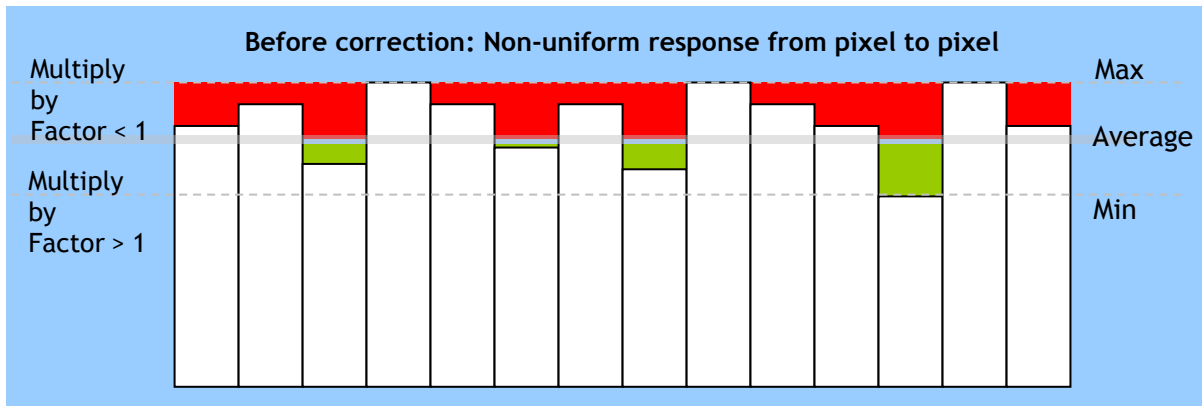

Fig.15 Conceptual drawing for PRNU correction (1)

To correct for PRNU, the camera's internal correction circuit captures one or several lines of data under non-saturated illuminated conditions which are not more than 80% of maximum (recommend level is half of maximum), and the average across the line is calculated. Based on this average, coefficients are then generated for each individual pixel. The coefficient has the function of multiplying the pixel output with a factor greater or less than 1. These coefficients are stored in a non-volatile memory, and are therefore maintained after power down.

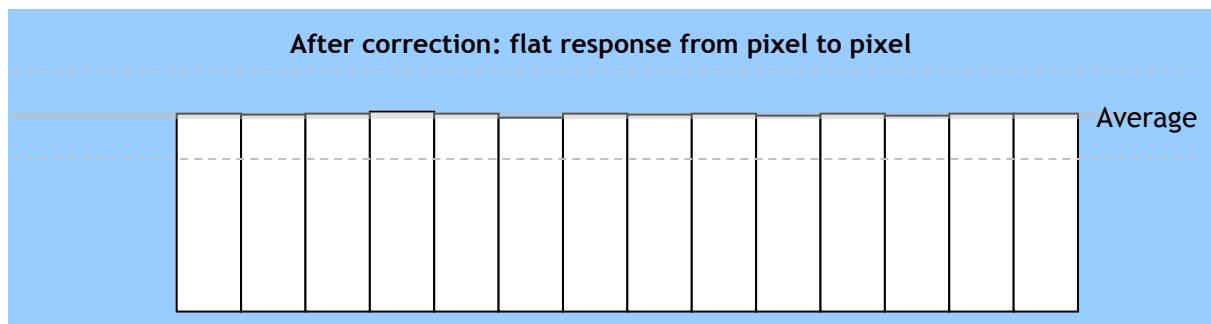

Fig.16 Conceptual drawing for PRNU correction (2)

6.2.8 DSNU (Dark Signal Non-Uniformity) correction

DSNU (Dark Signal Non-Uniformity) is, as the name implies, a non-uniformity of offset level of each pixel, which is *not* dependent on the incoming light.

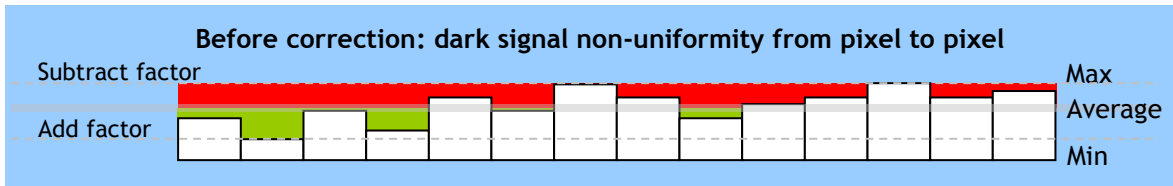

Fig.17 Conceptual drawing of DSNU correction

To correct for DSNU, the camera internal correction circuit captures one or several lines of data under dark conditions (the lens *must* be covered by a lens cap), and the average across the line is calculated. Based on the average, coefficients are then generated for each individual pixel. The coefficient has the function of adding or subtracting a value to the pixel output. These coefficients are stored in a non-volatile memory, and are therefore maintained after power down.

As the dark signal is highly dependent on the exposure time, this correction must be performed under the operating conditions (exposure time and line rate) that will be used by the application.

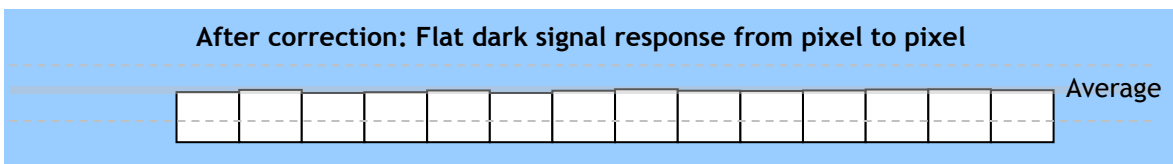

Fig.18 Conceptual drawing of DSNU correction

6.2.10 Shading correction

Shading is caused either by illumination with uneven distribution of light across the surface, or by reductions in the light transmission ratio towards the edges of a lens.

The shading correction incorporated in the camera will compensate for this effect by as much as 20% of the brightest signal.

Shading is not compensated for each individual pixel. The signal is averaged across groups of 8 pixels in relation to the whole line. The pixel response non-uniformity will be superimposed on the output also after shading correction has been performed. Therefore, it is recommended to perform PRNU correction before shading correction.

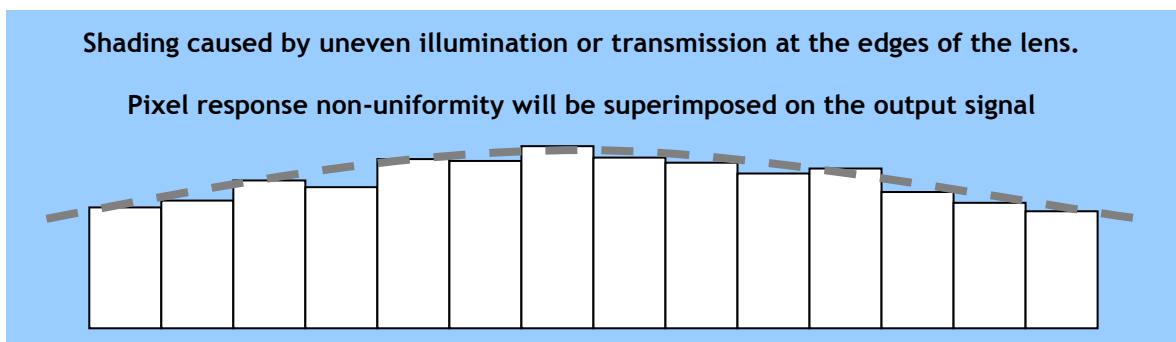

Fig.19 Shading correction

The shading correction has two ways to compensate, flat shading correction and color shading correction.

Flat shading correction (SDR=0):

Flat shading correction compensates red, blue, green and NIR signals to be flat output. The range of compensation is within plus-or-minus 20% as compared the brightest signal level. It may not compensate enough according to the lenses and/or lighting in use. As the default, the data which is activated in the factory is stored.

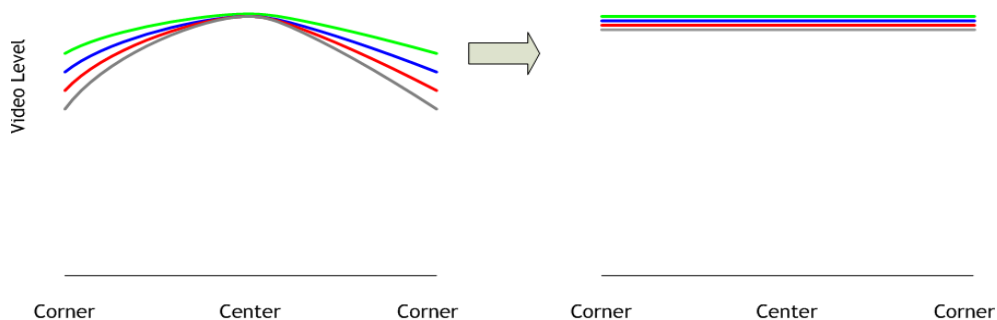

Fig.20 Flat shading correction concept drawing

Note:

- Depending on the optics and/or illumination used together with the camera, it may not be possible to fully compensate for shading.

Operating procedure for individual R, G, B and NIR channel shading correction:

1. Before making adjustment, approximately 30 minutes of warm up is required.
2. Make sure the output signal is not saturated (<80% of full output is recommended)
3. Set command PGC=2 and SDC=2.
4. Set command SDR to 0 to initiate shading correction.
5. If desired, set command PGR to 0 to activate flat-field (pixel gain) correction to correct for pixel response non-uniformity.
6. Again set SDR=0 after running the flat-field (pixel gain) correction

Color shading correction (SDR=1):

Color shading correction compensates red, blue and NIR signals to match with green signal characteristics. The camera does not store the reference data for color shading.

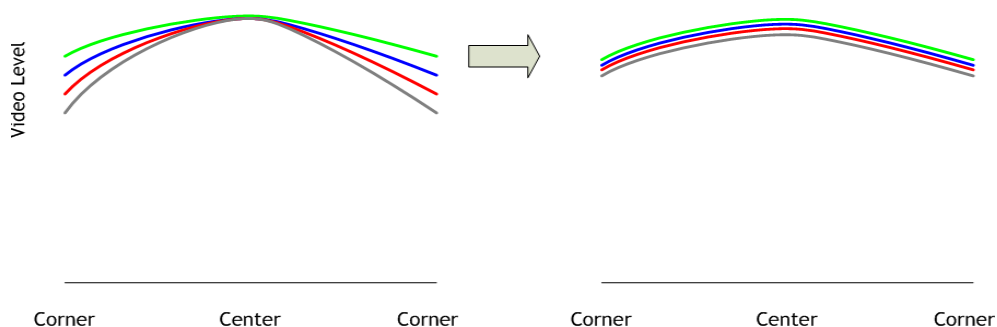

Fig.21 Color shading correction concept drawing

Note:

- For this function, no reference value is stored in the camera.

LQ-201CL

Operating procedure for individual R, B and NIR channel shading correction:

1. Before making adjustment, approximately 30 minutes of warm up is required.
2. Make sure the output signal is not saturated (<80% of full output is recommended)
3. Set command PGC=2 and SDC=2.
4. Set command SDR to 1 to initiate shading correction.
5. If desired, set command PGR to 0 to activate flat-field (pixel gain) correction to correct for pixel response non-uniformity.
6. Again set SDR=1 after running the flat-field (pixel gain) correction

Please note that before adjusting the shading, the white balance must be adjusted.

6.2.11 Lateral chromatic aberration

This function compensates for lateral chromatic aberration of lenses. Lateral chromatic aberration causes different line lengths for the R, G, B and NIR rays at the focal point. This function enables compensation data for up to three lenses to be stored. The compensation data specifies how many pixels the R, B and NIR channels should be stretched or shortened to match the line length of the G channel which is the reference. The range of correction is minus three pixels to plus three pixels. In order to realize this function, the LQ-201CL uses an FIR (finite impulse response) filter for R, B and NIR channels. The filter's response is determined by a set of 7 types of filter coefficients. The 2048 pixels that make up a line are divided in 16 blocks, with each block having 128 pixels. To compensate lateral chromatic aberration, the 7 types of coefficients are set for each block. In the factory, a default set of 112 data elements (7 types x 16 blocks) are calculated and stored.

1st Pixel

2048th Pixel

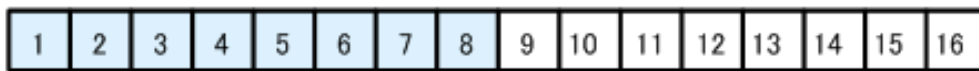

Pixel number in each block: 128 pixels

Note: Restrictions for this function

In order to adjust properly lateral chromatic aberration, the difference between G and R or B or NIR on right and left sides should be equal. Otherwise, the compensation may not be properly executed.

The following screen is used for creating up to three user-defined sets of lateral chromatic aberration data in the camera control tool.

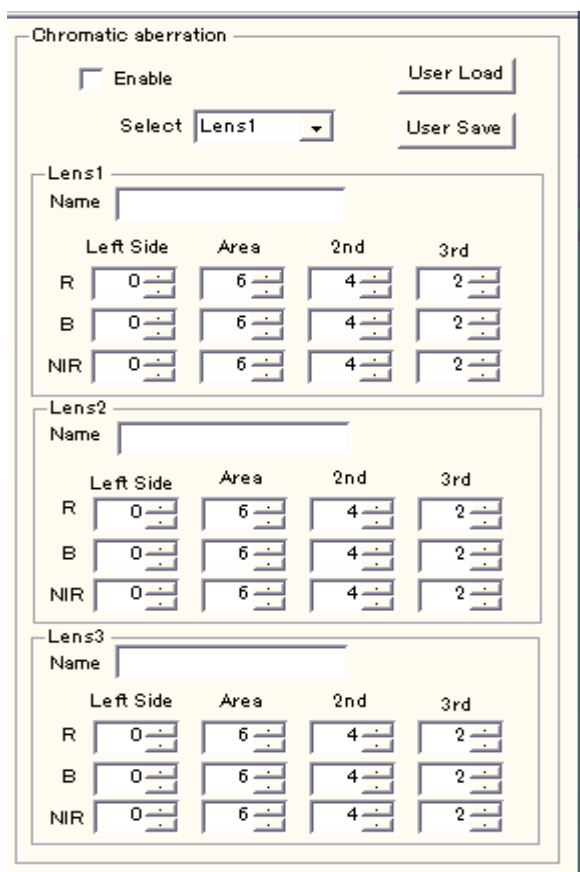

Fig. 22 Setting screen for lateral chromatic aberration

Setting procedure:

Please use the following steps.

1. Chromatic Aberration Enable
2. Select Lens 1, 2 or 3
3. Set the left side pixel
4. Set the area
5. Set the second block pixel
6. Set the third block pixel

Enable : Set chromatic aberration function ON or OFF.

Command MAV=0(OFF) and MAV=1(ON).

Lens 1,2,3 : Select a data set to use. Data for three lenses can be stored.

Change name : Instead of Lens 1, 2 and 3, specific names such as 28mm can be displayed. Max. 16 alpha-numeric characters can be used.

Left side pixel : Specifies by how many pixels the left edge of the image should be shifted. The maximum value is 3 pixels. A negative value extends the image by 1, 2 or 3 pixels. A positive value, narrows the image.

Values to set are L3,L2,L1,R1,R2 and R3.

L3 says to shift 3 pixels to the left and R3 says to shift 3 pixels to the right.

In case of Red, CABLR=[User Lens],[Shift value]

In case of Blue, CABLB=[User Lens],[Shift value]

In case of NIR, CABLIR=[User Lens],[Shift value]

The range of the shift value is -3 to +3.

The following is the result of a negative setting



The following is the result of a positive setting.

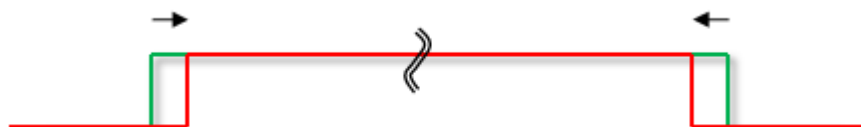

Fig. 23 Operation of the compensation

Area : This command specifies the area in which pixel shifting will be applied. The image is divided into 16 blocks, with each block representing 256 pixels. Enter a number from 1 to 8 to specify the inner edge of the pixel shifted area. The value is automatically mirrored on both the left and right sides of the image. If the left side pixel value is +/-1, only Area setting (1 to 6 blocks in fig. 25) is used and all pixels in this area will be shifted by 1 pixel. All pixels outside this area (7 and 8, white blocks) will remain un-shifted. If the left side pixel value is +/-2 or +/-3 use the 2nd Pixel Block and 3rd Pixel block fields to define a gradual shift from the edge to the center of the image.

2nd pixel block : If the left side pixel value is 2 or more pixels, enter a number in this field to specify the block where the compensation will transition from a 2-pixel shift to a 1-pixel shift. The value entered is automatically mirrored on both the left and right sides of the image. Blocks 1 to 4 in fig.25, are where the 2 to 1-pixel shift will be applied.

3rd pixel setting : If the left side pixel value is set at +/-3, enter a value in this field to specify the block where the compensation will transition from a 3-pixel shift to a 2-pixel shift. The value entered is automatically mirrored on both the left and right sides of the image. Blocks shown in blue (1 and 2 block) are where the 3-pixel shift will be applied.

Setting example:

Left side = -3 or 3

Area : 6, 2nd : 4, 3rd : 2

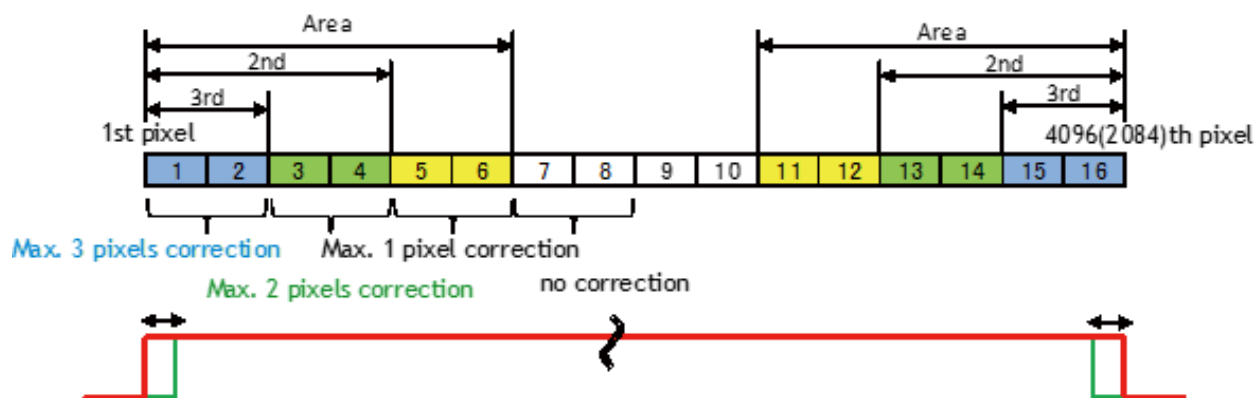

Fig. 24 Setting example

- Note: 1) If left side pixel is set at -2 or +2, only Area and 2nd can be configured. 3rd cannot be set.
 2) If left side pixel is set at -1 or +1, only Area can be configured.

Caution on calibration:

The object must be charts or materials which have clear and sharp discrimination of white and black edges. The volume of color difference in peripheral area is measured by using the image analysis software. Check how many pixels of R and B channels are shifted against G channel. In this function, maximum three pixels are compensated.

For instance, if R channel is shifted 1 pixel to the left in the left end of the image, this means “-1” and set the command CABLR to 1.

The compensation for the right side is automatically effected.

6.2.12 Aperture filter

LQ-400CL has a circuit for image enhancement in order to improve visible MTF. The compensation coefficient is a fixed value and cannot be changed. The factory default for this function is OFF. This function does not depend on the operating mode.

6.2.13 Binning

In this mode, the camera combines the charge collected in two adjacent pixels. This halves the effective resolution to 2048 pixels, but doubles the sensitivity. The line rate is not affected by binning. This function does not depend on the operating mode.

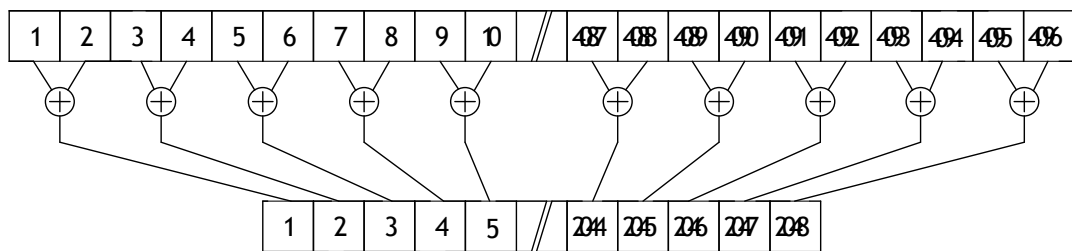

Fig.25 Binning reads out adjacent pixels at the same time

6.2.14 Sub-sampling

In this mode, every two effective pixels are read out. Accordingly, the read out rate is doubled. The FOV (Field Of View) is not changed versus full scan mode but the resolution becomes half.

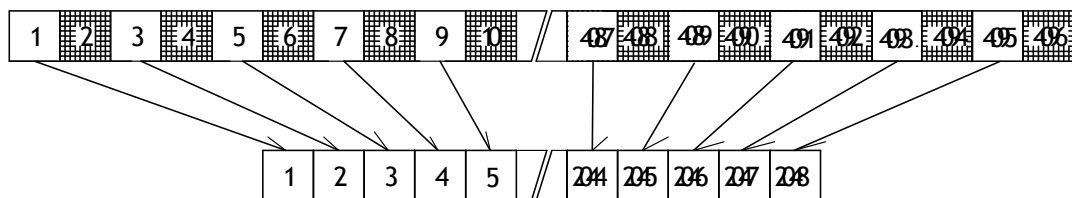

Fig.26 Sub-sampling reads out every two pixels

6.2.15 Windowing

In this mode, only the effective 2048 pixels in the center portion can be read out and accordingly, the readout rate is doubled. FOV becomes half as compared to the full pixel read out. 2048 pixels are a fixed number and cannot be varied by the user.

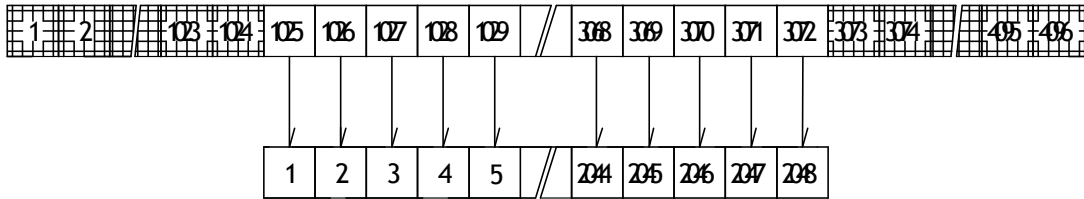

Fig.7 Windowing reads out only 2048 pixels at the center

6.2.16 Test pattern generator

LQ-400CL has four test pattern generators. In the following drawings, figures shown in () are for 8 bits output.

Color bar

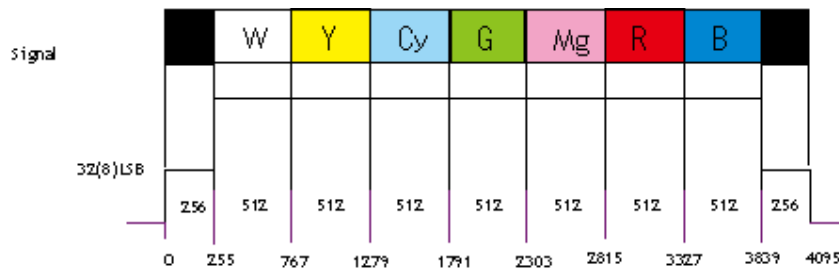

Fig.28 Color bar test pattern

Gray 1

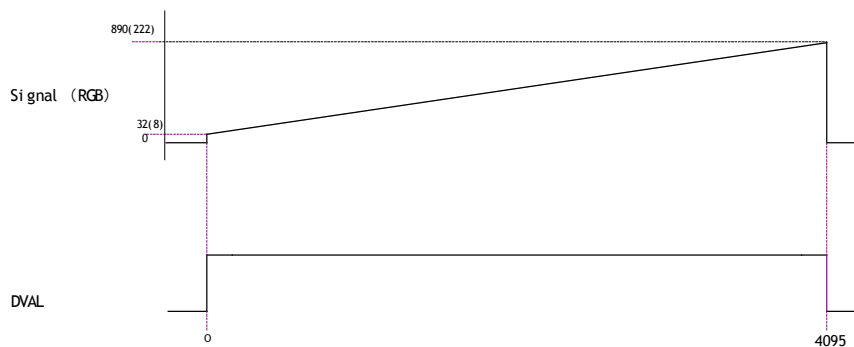

Fig.29 Gradation test pattern

LQ-201CL

Gray 2

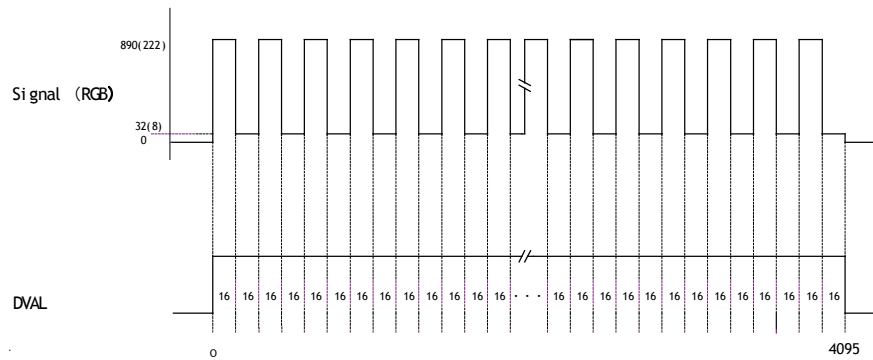

Fig.30 Multi burst test pattern

White

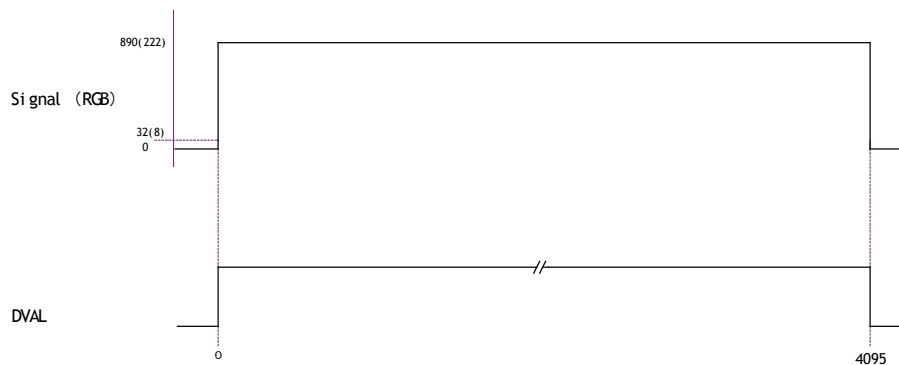

Fig.31 White test pattern

6.3. Operation modes

The LQ-400CL has the following operation modes.

	Trigger Mode		Trigger origin	
	Command	Description	Command	Description
1	TR=0	No-Shutter	TG=0	Internal
2			TG=1	External
3	TR=1	Shutter select	TG=0	Internal
4			TG=1	External
5	TR=2	Pulse width control	TG=1	-

6.3.1 Camera Default Settings

The following table shows the default settings of LQ-201CL

Item	Default setting	Value
Gain	Master mode B/G/R/NIR	0dB
Black	Master mode B/G/R/NIR	8LSB
Trigger Mode	No-shutter	
Trigger Origin	Internal	
Auto Reset Mode	ON	
Input	Camera Link	
Polarity	Active Low	
Line Rate		24000
Bit Allocation	8-bit	
Binning	OFF	
Test Pattern	OFF	
Noise Reduction	OFF	

6.3.2 No-Shutter mode with Internal Trigger

In this mode, the exposure and readout are activated by the trigger pulse generated internally. As the accumulation control is done by the internal counter, the accumulation is not affected by the trigger jitter.

In this mode, the accumulation period depends on the trigger interval. Accordingly, if trigger interval becomes longer, the sensitivity is increased.

To use this mode:

Set function	Trigger mode, No-Shutter	TR=0
	Trigger origin, Internal	TG=0
	Line rate	LR=2544 to 1260000
		(30.29 μ s to 15.0 ms in 11.9 ns increments)

Optional functions when using this mode:

One-push auto line rate	AR=0
Auto line rate reference	AL=0 to 1023
One-push white balance	WB

Important Note

- The “one-push auto line rate” function is not recommended for continuous web applications, as the speed of motion needs to be adjustable in order to maintain the aspect ratio of the image.
- Only gain based one-push white balance functions (WB) are available with this mode.

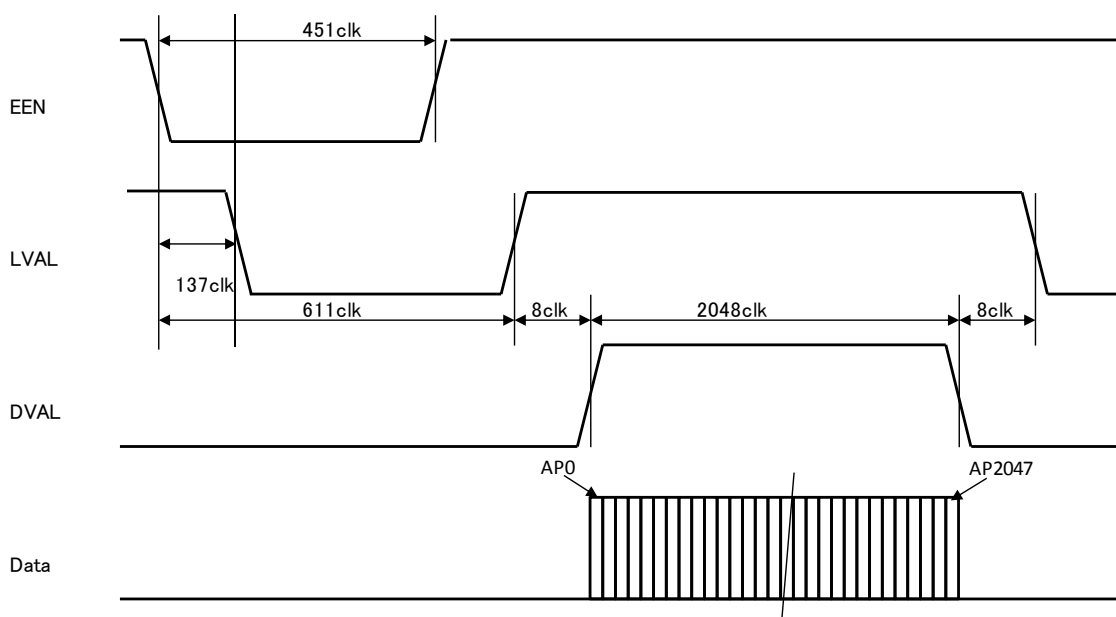

Fig. 32 No-Shutter / Internal Trigger mode

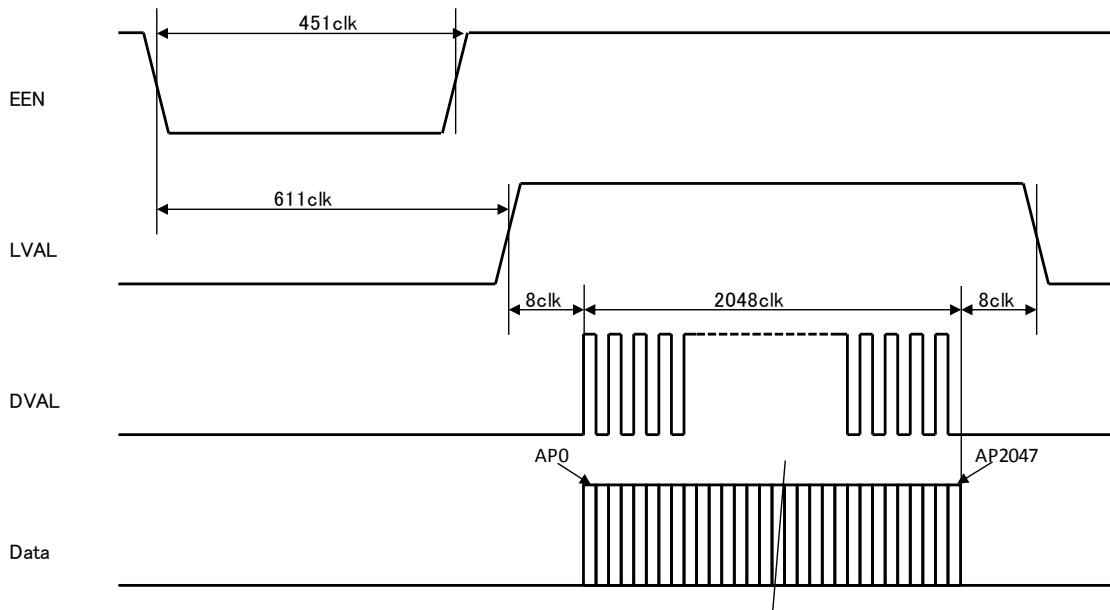

Fig.33 No-Shutter mode / Binning/ Internal

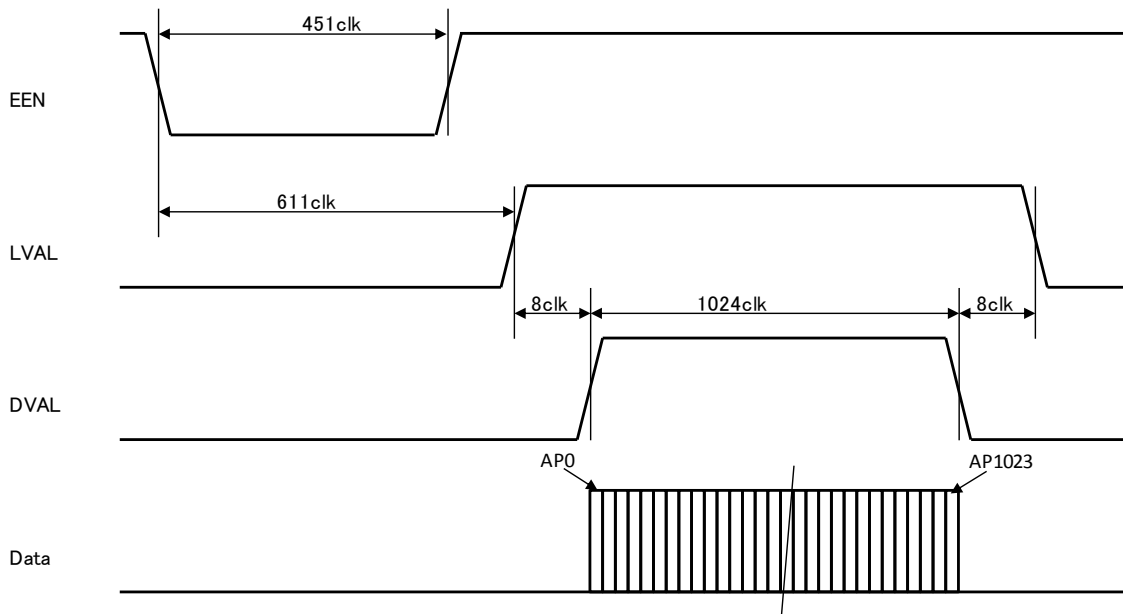

Fig.34 No-Shutter /Sub-sampling and Window/ Internal

6.3.3 No-Shutter mode with external trigger

In this mode, the accumulation and readout is activated by an external trigger pulse. The exposure period depends on the trigger interval and if the trigger interval becomes longer, the sensitivity is increased.

To use this mode:

Set function	Trigger mode, No-Shutter	TR=0
	Trigger origin, external	TG=1
	Trigger input	TI=0 or 1

Important note:

- In this mode, the shutter cannot be used.
- Only gain based one-push white balance functions (WB) are available with this mode.
- The jitter generated in the trigger input causes a variation of exposure time.

- Minimum trigger interval

Scan mode	Trigger input via	Minimum interval (μ s)
Full/Binning	Camera link	30.8
	12-pin	35.3
Sub-sampling/windowing	Camera link	18.9
	12-pin	23.4

- Minimum trigger pulse width

Trigger input via	Minimum trigger pulse width
Camera link	500 ns
12-pin	5 μ s

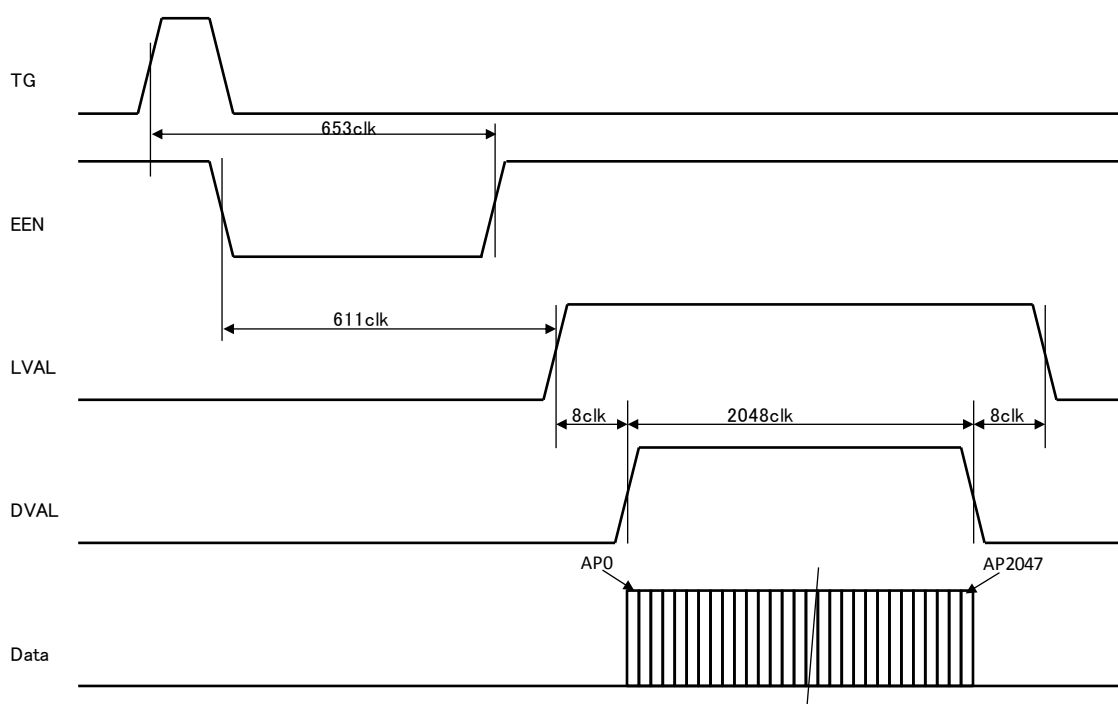

Fig. 35 No-Shutter mode with external trigger

LQ-201CL

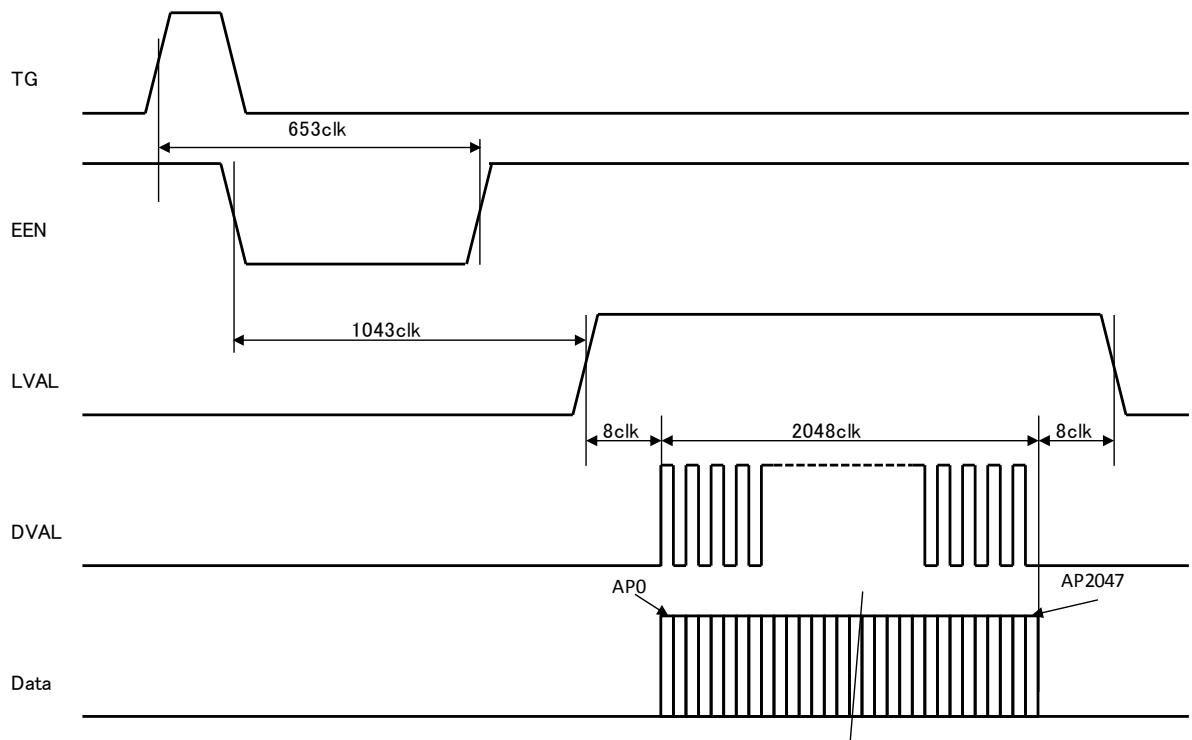

Fig. 36 No-Shutter mode /Binning/ External

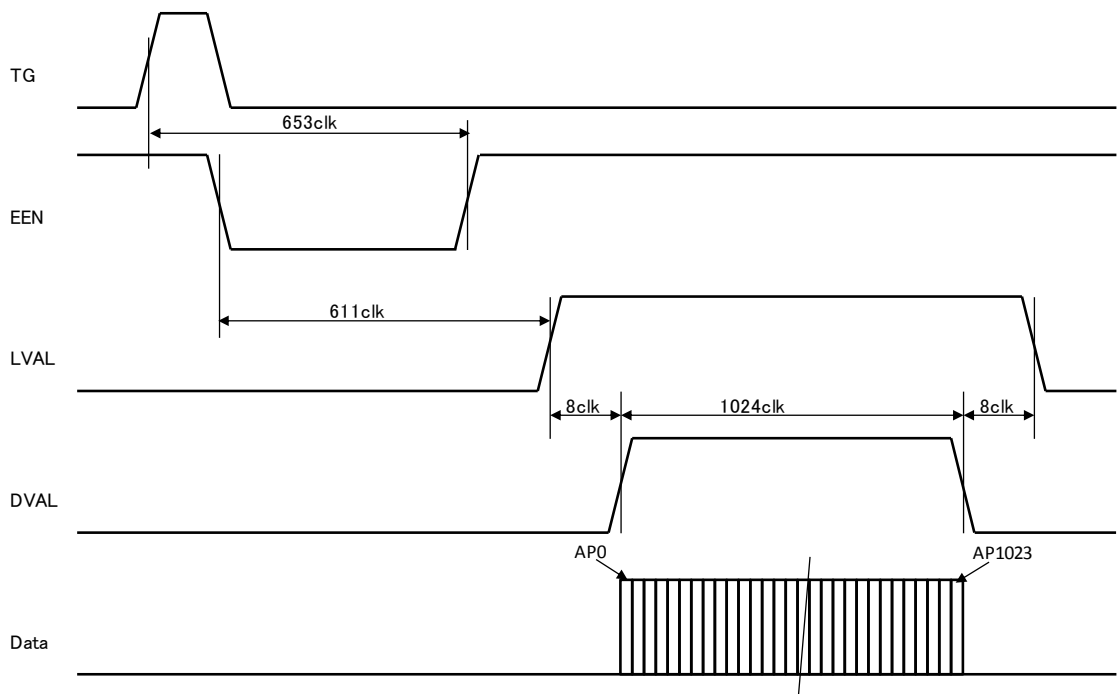

Fig.37 No-Shutter mode /Sub-sampling and Window/ External

6.3.4 Shutter-Select mode with internal trigger

In this mode, the exposure and readout is activated by the trigger pulse generated internally. As the accumulation control is done by the internal counter, the accumulation is not affected by the trigger jitter.

In this mode, the exposure time of R, G, B and NIR channel can be adjusted independently.

To use this mode:

Set function

Trigger mode, Shutter-Select	TR=1
Line rate	LR=2544 to 1260000 (30.29 μ s to 15.0 ms in 11.9 ns increments)
Trigger origin, internal	TG=0
Individual R, G, B and NIR exposure	EI=0(individual) EI=1(tracking with G)
Programmable exposure	PER/PEG/PEB/PEIR=800 to 1259549 (9.52 μ s to 14.99 ms in 11.9 ns increments)

Important note:

- If using individual exposure, the EEN signal represents the channel with the longest exposure time
- For one-push white balance, both shutter gain (AH) and gain(AW) are effective.

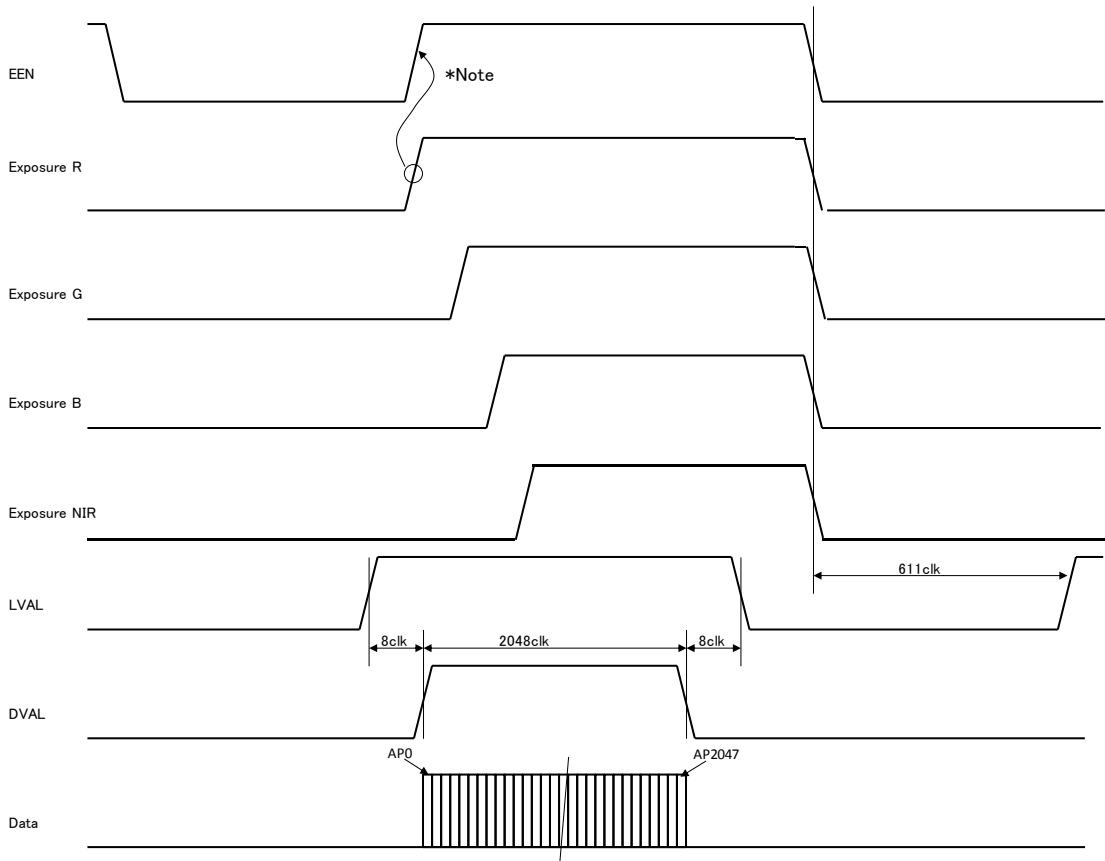

Note: EEN uses channel with the largest exposure value

Fig.38 Shutter-Select mode / Internal

LQ-201CL

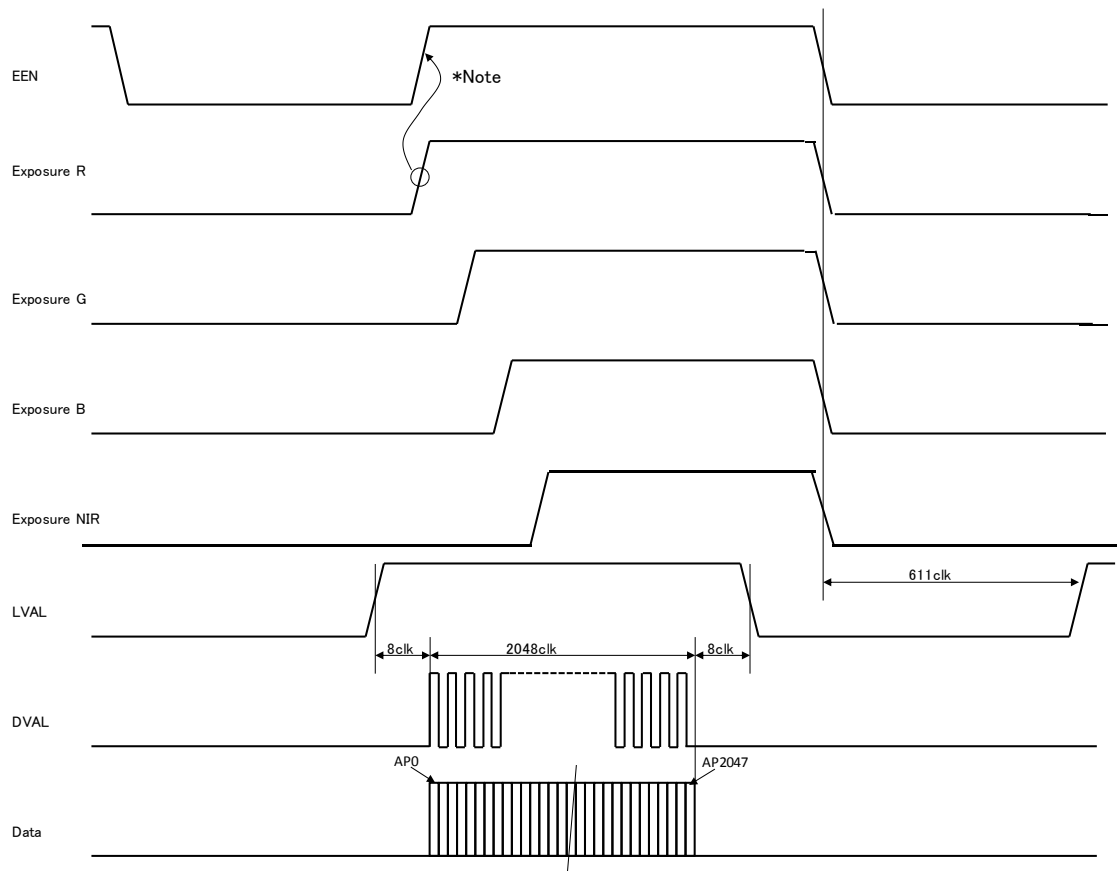

Note: EEN uses channel with the largest exposure value

Fig. 39 Shutter-Select mode / Binning / Internal

LQ-201CL

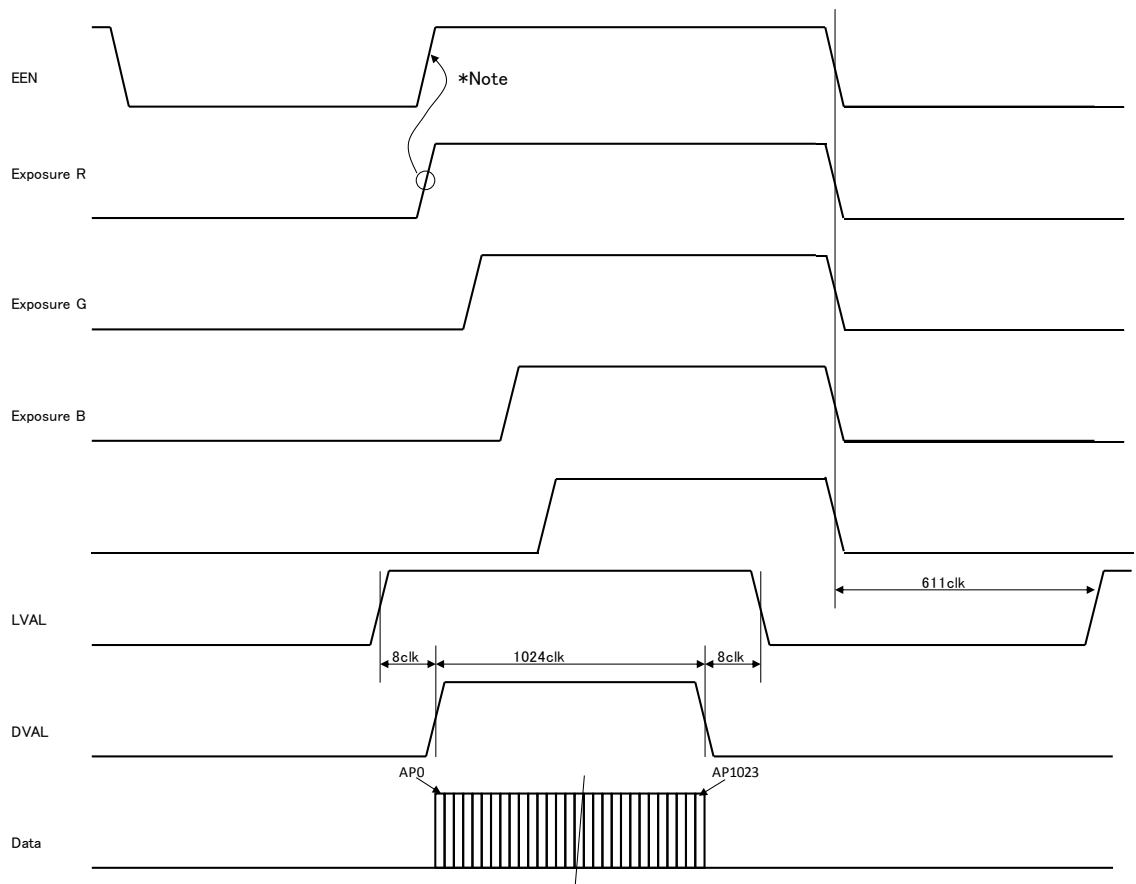

Note: EEN uses channel with the largest exposure value

Fig.40 Shutter-Select mode/Sub-sampling and Window/ Internal

6.3.5 Shutter-Select mode with external trigger

In this mode, the exposure and readout is activated by the external trigger pulse. In this mode, the exposure time of R, G, B and NIR channel can be adjusted independently.

To use this mode:

Set function

Trigger	TR=1
Trigger origin, external	TG=1
Individual R, G, B and NIR exposure	EI=0(individual) EI=1(tracking with G)
Programmable exposure	PER/PEG/PEB/PEIR=800 to 1259549 (9.52 μ s to 14.99 ms in 11.9 ns increments)

Important note:

- If using individual exposure, the EEN signal represents the channel with the longest exposure time
- The minimum trigger interval

Scan mode	Trigger input via	Minimum interval (μ s)
Full/Binning	Camera link	30.8
	Hirose 12-pin	35.3
Sub-sampling/windowing	Camera link	18.9
	Hirose 12-pin	23.4

- The minimum trigger pulse width

Trigger input via	Minimum trigger pulse width
Camera link	500 ns
Hirose 12-pin	5 μ s

- For one-push white balance, both shutter gain (AH) and gain (AW) are effective.

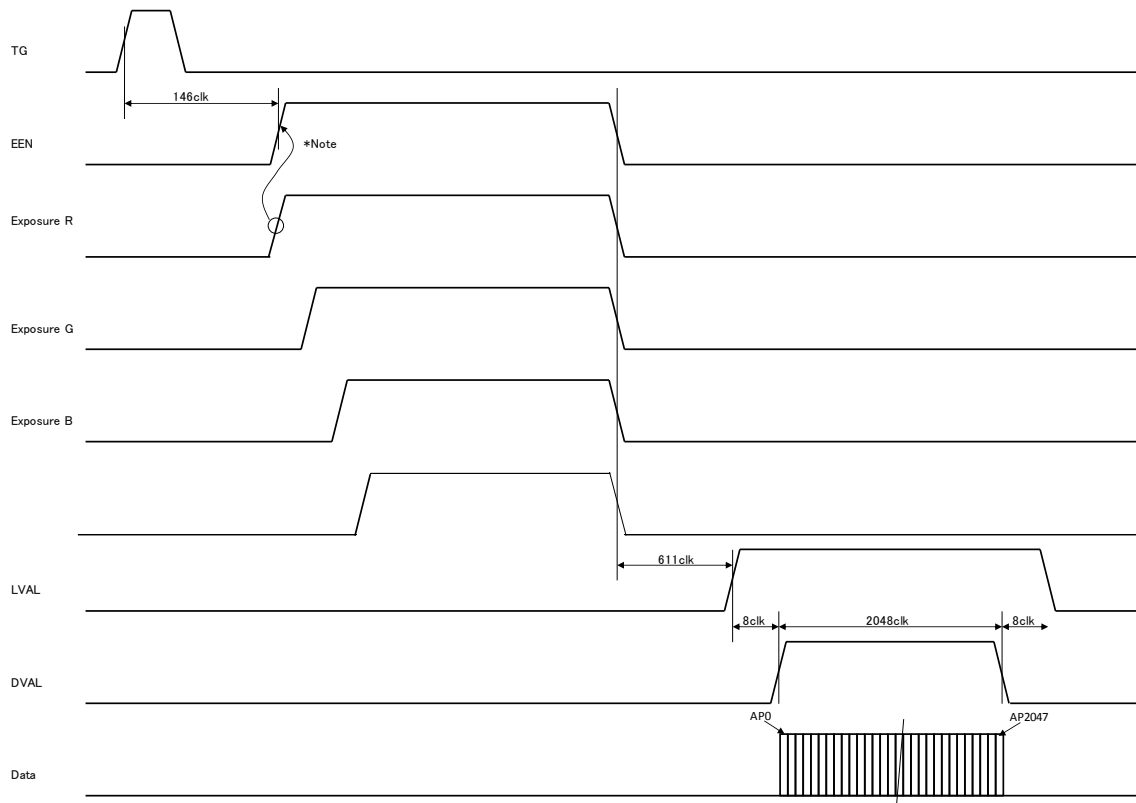

Note: EEN uses channel with the largest exposure value

Fig. 41 Shutter-Select mode with external trigger (and individual exposure)

LQ-201CL

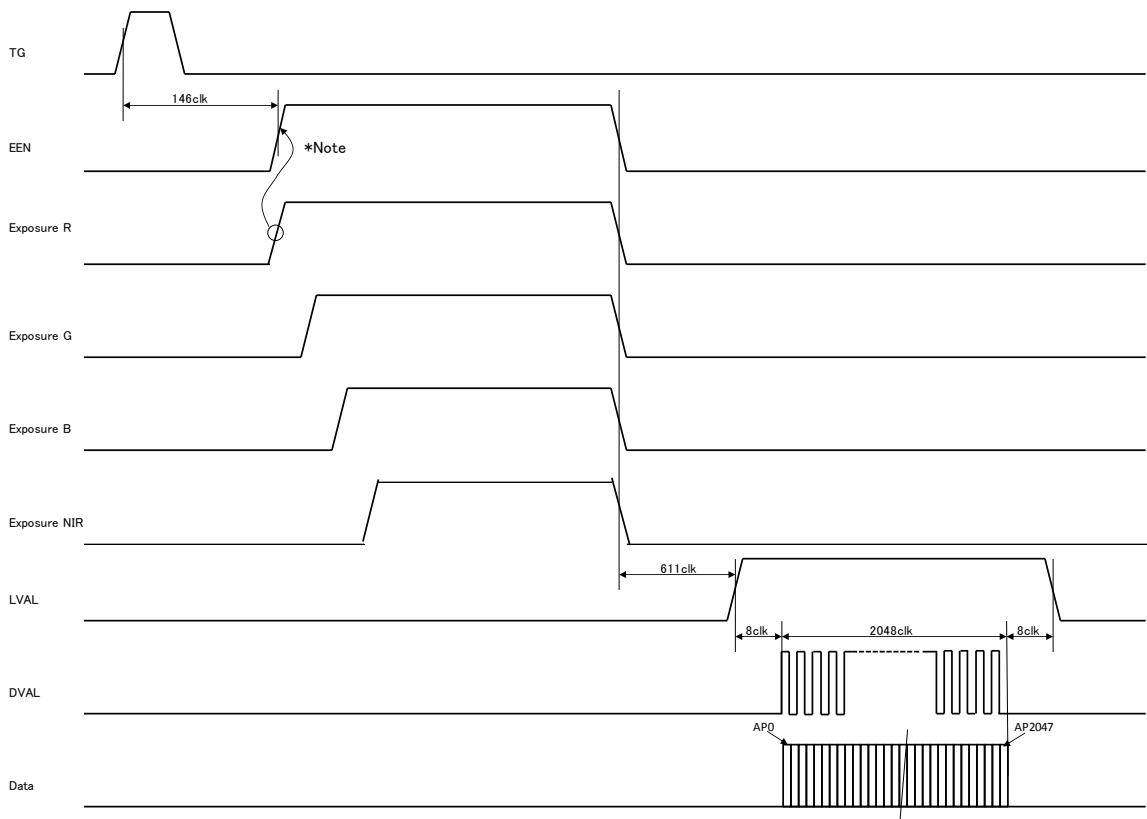

Note: EEN uses channel with the largest exposure value

Fig.42 Shutter-Select mode /Binning /External

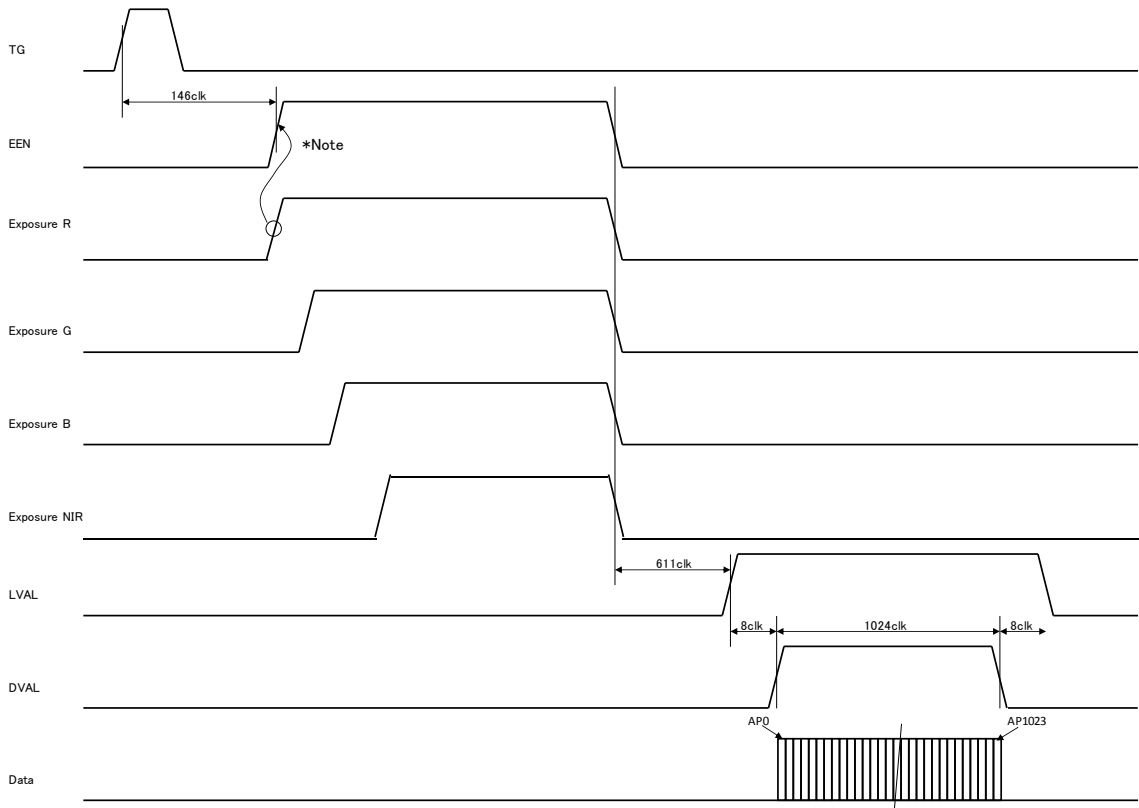

Note: EEN uses channel with the largest exposure value

Fig.43 Shutter-Select /Sub-sampling and Window/ External

6.3.6 Pulse Width Control (PWC) mode

In this mode, the exposure time and readout are activated by the external trigger pulse. The exposure time depends on the pulse width provided.

To use this mode:

Set function Trigger mode, PWC TR=2

Important Note:

- The minimum trigger interval

Scan mode	Trigger input via	Minimum interval (μs)
Full/Binning	Camera link	Exposure time + 30.8
	12-pin	Exposure time + 35.3
Sub-sampling/windowing	Camera link	Exposure time + 18.9
	12-pin	Exposure time + 23.4

- The available input trigger pulse width

Trigger input via	available input trigger pulse width
Camera link	$2\mu\text{s} \sim 1\text{s}$
12-pin	$50\mu\text{s} \sim 1\text{s}$

- One-push white balance by gain setting only.
- When the one-push white balance has been initiated and the rear panel LED shows orange, the camera must receive continuous external trigger pulses corresponding to the frequency and duty cycle used in the application.

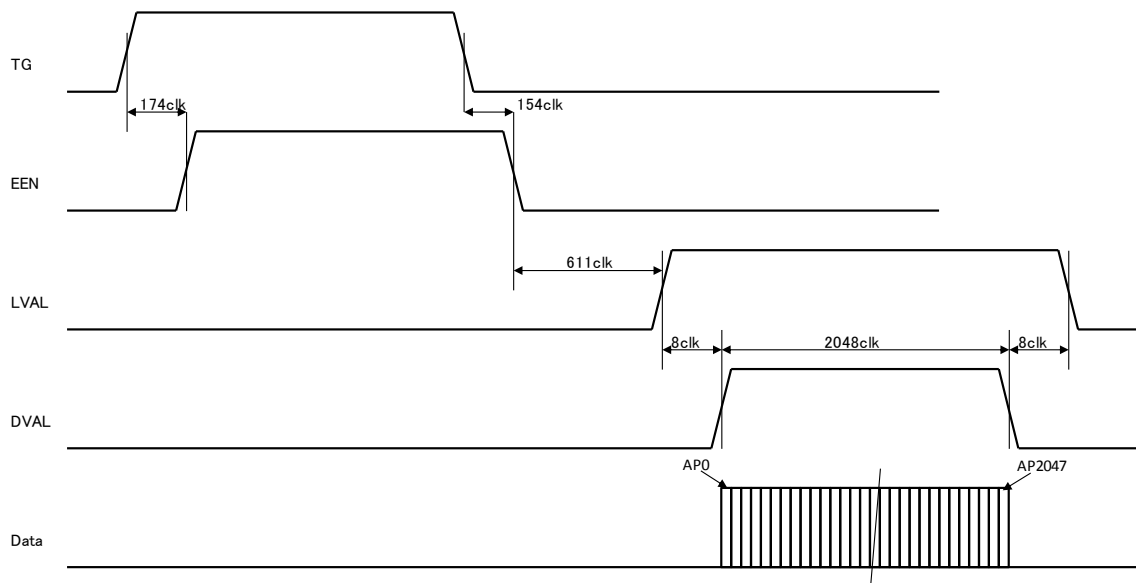

Fig. 44 Pulse Width Control mode

LQ-201CL

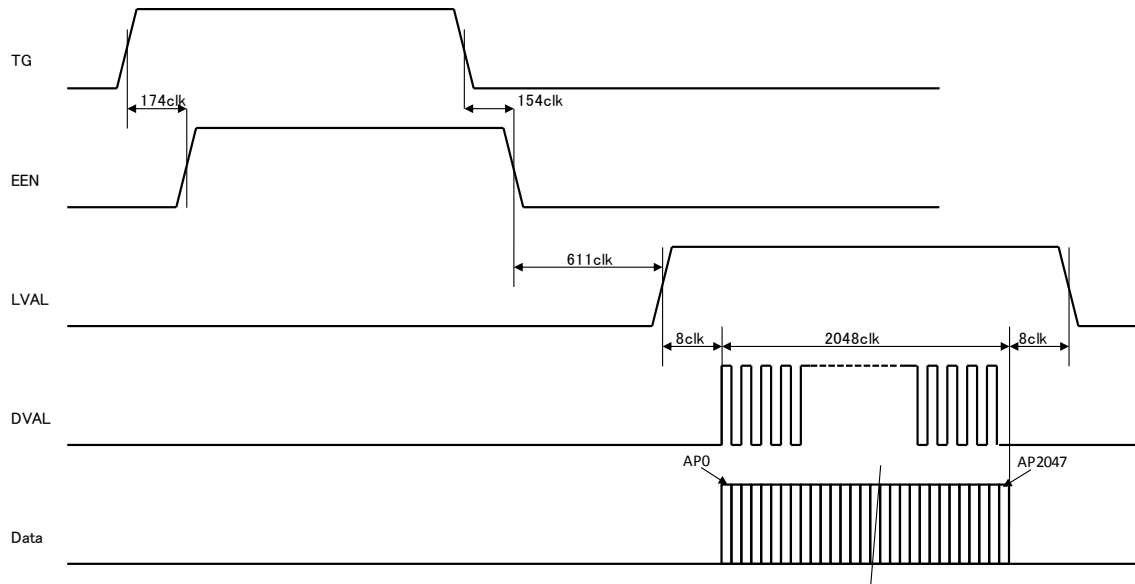

Fig.45 PWC mode /Binning

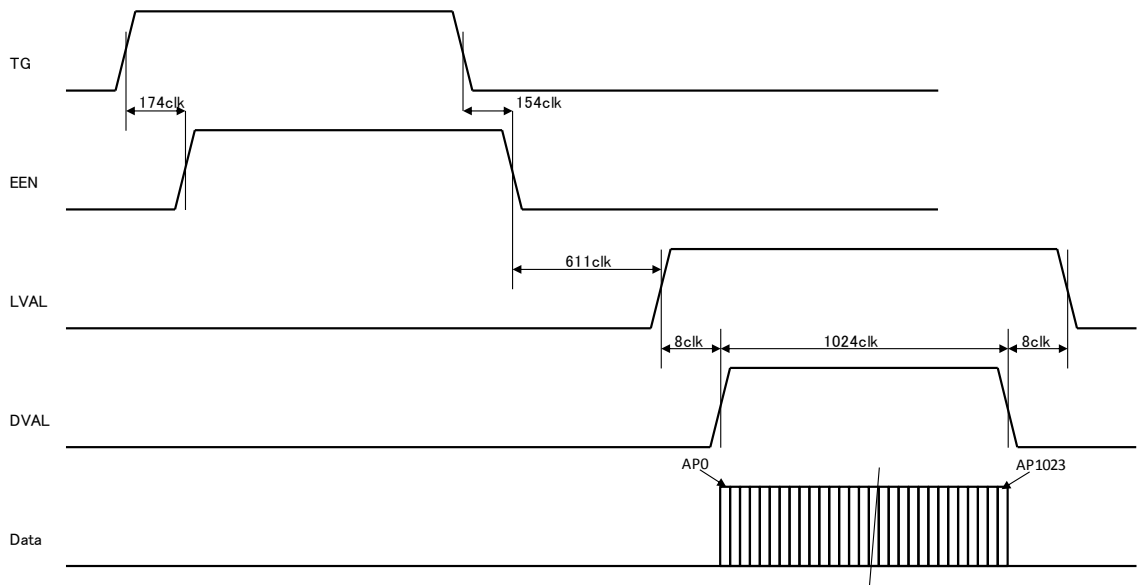

Fig.46 PWC mode /Sub-sampling and Window

6.3.7 Compatibility of trigger modes and functions

Trigger		Image output format				Gain		Offset	
Mode	Origin	Full resolution	Binning	Sub sampling	Windowing	Master Tracking	Individual	Master tracking	Individual
No-shutter	Internal	⊙	⊙	⊙	⊙	⊙	⊙	⊙	⊙
	External	⊙	⊙	⊙	⊙	⊙	⊙	⊙	⊙
Shutter-Select	Internal	⊙	⊙	⊙	⊙	⊙	⊙	⊙	⊙
	External	⊙	⊙	⊙	⊙	⊙	⊙	⊙	⊙
PWC	External	⊙	⊙	⊙	⊙	⊙	⊙	⊙	⊙

Trigger		Shading correction		AWB		Test pattern	Auto Line Rate
Mode	Origin	FLAT	COLOR	Gain	Shutter		
No-shutter	Internal	⊙	⊙	⊙	×	⊙	⊙
	External	○	○	○		○	×
Shutter-Select	Internal	⊙	⊙	⊙	⊙	⊙	⊙
	External	○	○	○	○	○	×
PWC	External	○	○	○	×	○	×

Note: ⊙ They can be used together.

○ They can be used together but when the compensation data is acquiring or test signal is displaying, the trigger pulse should be continuously input.

× They cannot be used together.

6.3.8 Trigger modes and auto white balance modes matrix table

	Trigger	Control	
		One-push gain	One-push shutter
No-shutter	Internal	yes	No
	External	yes	No
Shutter-Select	Internal	yes	yes
	External	yes	yes
PWC	Internal	yes	No

7. Functions listed alphabetically by command acronyms

The following is not a complete list. Please refer to Chapter 8, Serial Communication and Command List, for the details.

7.1 Command AHRS - Request Status After One-Push AWB

This command returns the status of the one-push AWB function, with the following parameters:

- 0=AWB not completed yet
- 1=Succeeded
- 2=Error1: Green image too bright
- 3=Error2: Green image too dark
- 4=Error3: Timeout occurred

7.2 Command AL - Automatic Line Rate Reference Level

This command sets a target luminance level when command AR is activated.

- Settings: 0 to 1023 (for 40-bit)
- Applicable modes: No-shutter with internal trigger
Shutter-Select with internal trigger
- Associated functions: Command AR

7.3 Command AR - Automatic Line Rate Setting

The line rate can be adjusted from 1L to 1024L. This function will calculate and set the line rate of the camera based on the Automatic Line Rate Reference Level (as set in command AL) and the scene illumination. Please note that the aspect ratio of the scanned object will change as the line rate is changed.

- Settings: 0 (activate automatic process)
- Applicable modes: No-shutter with internal trigger
Shutter-Select with internal trigger
- Associated functions: Command AL

Note

- The data can be stored in the camera memory for next start up.

7.4 Command ARST - Auto Reset Mode

This function sets the reset mode to be used

- Settings 0: OFF
 - 1: Auto Reset
 - 2: Auto Interval
- Factory default is 0 (off).

1. Auto Reset Mode

In No Shutter External mode, when a trigger pulse does not occur after more than 52 ms, and the first trigger pulse is input after this absence, the video signal which was exposed during the trigger absence is output. If Auto Reset Mode is set to ON, the video, LVAL and DVAL during the trigger absence are not output and when the second trigger is input, the video, LVAL and DVAL are output again.

In Shutter Select mode, when the first trigger is input, the camera is exposed during setting exposure time and the video is output regardless of the setting of Auto Reset Mode. The following shows the timing.

Auto Reset OFF

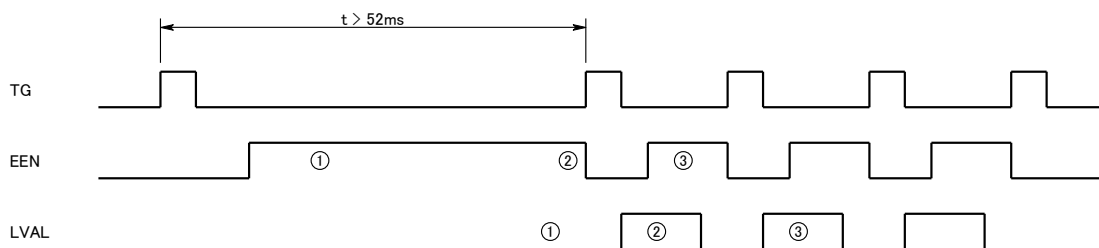

Auto Reset ON

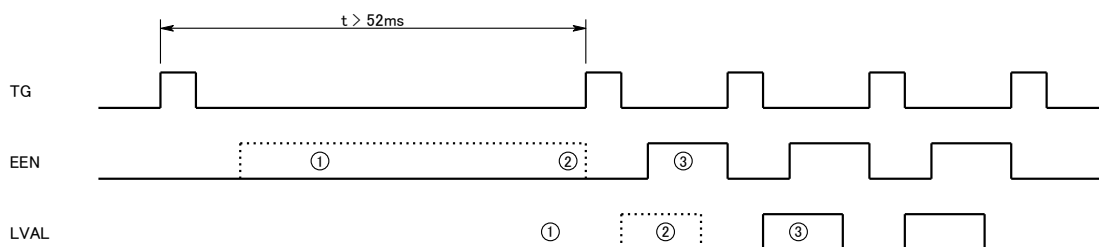
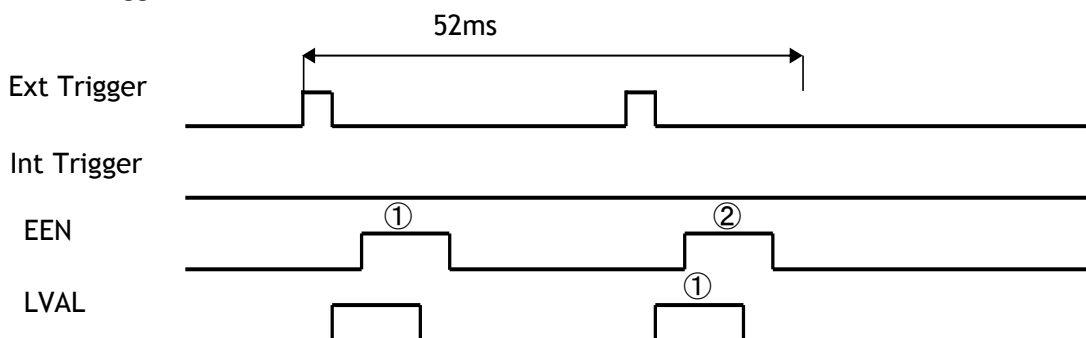

Fig.47 Auto Reset Mode timing

2. Auto Interval

In Shutter-Select External mode, if a trigger pulse does not occur after more than 52 ms, the signal-to-noise ratio may deteriorate due to the increasing dark current. If Auto Interval is enable, an internal trigger is generated every 52 ms and the accumulated electrons are discharged. This prevents deterioration of the signal-to-noise ratio.

1. If the trigger interval is less than 52 ms



2. If the trigger interval is longer than 52 ms

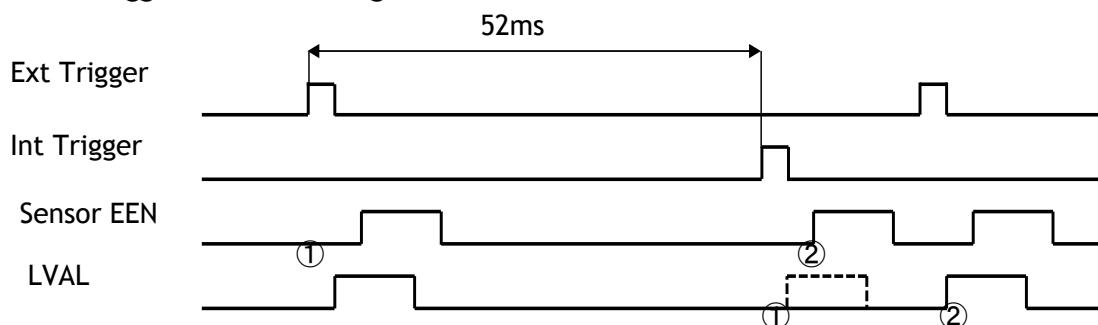

3. If the external trigger timing happens to be the same as the internal trigger timing, the internal trigger is generated again as shown below. In this case, jitter may occur.

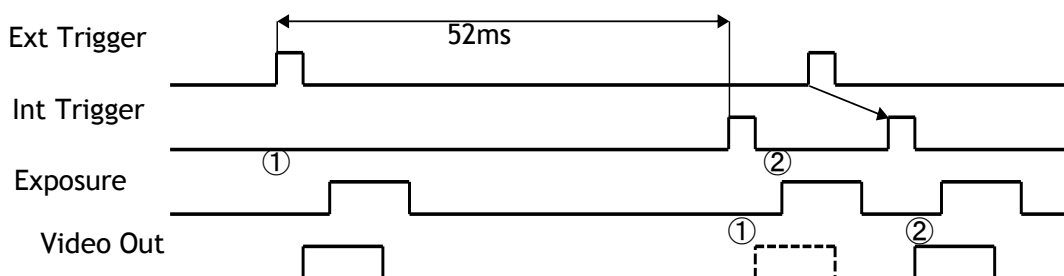

Fig. 48 Auto Interval Timing

7.5 Command AH - Activate One-Push Auto White Balance (AWB) - Shutter

By sending this command via the serial communication, the *shutter based* One-Push AWB function is activated. The white balance function takes approximately 3 seconds to complete. During this time the rear panel LED will show orange.

This function operates in two steps. First the red-to-green channel difference and the blue-to-green channel difference are calculated separately. Then the exposure times of the blue and red channels are automatically adjusted, to obtain the same output level on all three channels.

Settings: 0 = activate automatic process
 Applicable modes: Shutter-Select mode only
 Associated functions: Command WB

Note:

- When color temperature of illumination exceeds the range of adjustment, proper white balance may not be obtained.
- The data can be stored in camera memory for use at next start up.
- This function can work in external trigger mode.
- The S/N ratio of the output will remain constant for all channels

7.6 Command **AW** - Activate One-Push Auto White Balance (AWB) - Gain

By sending this command via the serial communication, the *gain based* One-Push AWB function is activated. This function can also be initiated by pressing the rear panel button. The white balance function takes approximately 3 seconds to complete. During this time the rear panel LED will show orange.

This function operates in two steps. First the red-to-green channel difference and the blue-to-green channel difference are calculated separately. Then the gains of the blue and red channels are automatically adjusted, to obtain the same output level on all three channels.

Settings:	0 = activate automatic process
Applicable modes:	All
Associated functions:	Command WB Rear panel one-push WB button.

Note:

- When color temperature of illumination exceeds the range of adjustment, proper white balance may not be obtained.
- The data can be stored in camera memory for use at next start up.
- This function can work in external trigger mode.
- The S/N ratio of the output will change as a result of this function.

7.7 Command **BA** - Bit Allocation

This function lets the user select whether the video data is presented as 4 x 8 (32)-bit or 4 x 10 (40)-bit in the Camera Link output. The internal processing in the camera is based on a 12-bit A/D signal. The 32-bit and 40-bit function removes the least significant bits from the 12-bit signal.

Settings:	0= 4 x 8-bit, 1= 4 x 10-bit
Applicable modes:	All

7.8 Command **BI** - Binning

This function reduces the number of pixels to 2048 without affecting the line rate. Two adjacent pixels are combined at the output stage and read out as one pixel. Sensitivity is doubled as a result of binning.

Settings:	1=binning on, 0=binning off
Applicable modes:	All

Note

- Setting data is stored in camera memory for use at next start up
- This function is available for all modes.

7.9 Command BL - Master Black Level

This command is a global black level adjustment for all channels. There are two adjustment ways, one is “Master Tracking” and the other is “Individual”. The adjustable range for master black is 0 LSB to 64 (16) LSB. The number in parenthesis is valid for 40-bit output.

Master Tracking
Settings: Master (G): 0 to 64

Individual
Settings: G ch: 0 to 64

Associated functions: Commands BLR, BLB, BLIR

7.10 Commands BLR, BLB and BLIR - Black Level Red, Blue and NIR

In conjunction with Command BL, these commands allow individual setting of the black level in all channels.

Master Tracking
Settings: -64 to 63
This parameter is adjusted to Master setting value

Individual
Settings: 0 to 64

Associated functions: Command BL

7.11 Command BLM - Black Level Mode

Select the black level adjustment method

Settings: 0=Master tracking (Factory default)
1=Individual

7.12 Command CABR, CABB and CABIR Chromatic aberration Red, Blue NIR

These commands compensate the size of image on sensor. The size of image on the sensor may be different on R,G,B and NIR channels due to the prism optics which is called lateral chromatic aberration.

There are 112 data elements. In order to write all data, this command must be written 112 times. Please refer to the chapter 6.2.11 for the details of this function

Associated commands: MAV, MAVCG, CABN1, CABN2, CABN3, CABLR, CABLB, CABLIR
CABAR, CABAB, CABAIR, CABSR, VABSB, CABSIR, CABTR, VABTB
CABTIR

7.13 Command EI - Interlocked R, G, B & NIR Exposure

When this function is enabled (interlocked), exposure time for all four channels is selected by setting the green channel and the red, blue and NIR channels will track.

To obtain white balance, adjust red and blue channels using PER and PEB. Thereafter, it is possible to adjust overall exposure time by using the command PEG. The red and blue channels will track the green channel proportionally, thus maintaining white balance settings.

Settings: 0= OFF(independent R, G,B and NIR settings)
1= R, B and NIR channel tracking with G
Associated functions: Commands PER, PEG, PEB and PEIR - Programmable Exposure
Applicable modes: Shutter-Select mode only

7.14 Command GA - Master Gain Level

This function is a global gain adjustment for all channels. There are two ways to adjust gain: one is “Master Tracking” and the other is “Individual”. Command GM selects a required mode. The gain setting is done in the analog domain where 1LSB equals 0.01dB.

Master Tracking
Settings: Master (G): 0 to 802
Individual
Settings: G: -402 to 1404

Associated functions: Commands GAR, GAB, GAIR - Gain level red, blue, and NIR.

7.15 Commands GAR, GAB and GAIR - Gain Level Red, Blue and NIR.

In conjunction with the Command GA, this function allows the individual setting of gain for all channels, or it can be used for fine adjustment after one push white balance is executed. It is important to note that increasing the gain will lead to an increased noise level and reduced S/N-Ratio.

Master Tracking
Settings: -402 to 602(-4dB to +6dB)
Individual
Settings: -402 to 1404 (-4dB to +14dB)

Associated function: Command GA - Master gain level
Applicable modes: All modes
Note: Setting data is stored in camera memory for use at next start up

7.16 Command GM - Gain Mode

Selects gain mode.

Settings: 0=Master Tracking (Factory default)
1=Individual

7.17 Command HPFC - Aperture Control

This command enables Aperture Correction to enhance the edge of the picture. The level is pre-set in the factory.

Settings: 0= OFF, 1= ON

7.18 Command LR - Line Rate (Scan Rate)

This function is used only when there is not an external trigger pulse (e.g. from an encoder)

available. It allows the user to program the line rate, in order to match the speed of the object being scanned. In the No-shutter mode, the exposure time is directly proportional to the line rate ($T_{exp} = 1/\text{line rate}$)

Settings: Full resolution/Binning
2544 to 1260000, in 11.9 ns increments
Sub-sampling/Windowing
1520 to 1260000 in 11.9 ns increments
Associated functions: Trigger origin, TG=0
Applicable modes: No-shutter with internal trigger (TR=0)
Shutter-Select with internal trigger (TR=1)

Note

- The data can be stored in the camera memory for next start up.

7.19 Command MAV - Chromatic Aberration Control

This command enables or disables chromatic aberration adjustment for each channel.

Settings: = OFF, 1= ON

7.20 Command MAVCG - Chromatic Aberration Select

This command selects the lens to be used if the compensation data is stored. The data for three lenses can be stored and used.

Settings: 0= User1 Lens
1= User2 Lens
2= User3 lens

Note: Name of User 1, 2 or 3 can be modified to particular lens type name.

7.21. Command NR - Noise Reduction

Noise levels less than 16 LSB (4LSB) which are superimposed on the video signal will be eliminated. The deterioration of spatial frequency is minimized. The improvement of signal-to-noise ratio will be 3dB as the maximum although it depends on the object. Figure in () is for 8-bit output.

Settings: 0=ON, 1=OFF

7.22 Command OS1,2,3,4,5,6 - Camera Link Video Output Select

Settings: OS1 0= Rch 1= Gch 2=Bch 3= NIR ch (Default 0)
OS2 0= Rch 1= Gch 2=Bch 3= NIR ch (Default 1)
OS3 0= Rch 1= Gch 2=Bch 3= NIR ch (Default 2)
OS4 0= Rch 1= Gch 2=Bch 3= NIR ch (Default 3)
OS5 0= Rch 1= Gch 2=Bch 3= NIR ch (Default 0, only 8-bit)
OS6 0= Rch 1= Gch 2=Bch 3= NIR ch (Default 0, only 8-bit)

7.22 Command PBC - Enable Pixel Black (FPN) Correction

This command enables (or disables) the “pixel black level” correction function, which compensates for Dark Signal Non Uniformity / Fixed Pattern Noise (DSNU / FPN) for individual pixels.

Settings: 0 = Off (Default)
1 = Factory setting
2 = user area
Associated functions: Command PBR
Applicable modes: All

7.23 Command PBR - Run Pixel Black Correction and Store to User Area

This command initiates the “pixel black level” correction function, and stores the settings in the user area. When this function is activated, lens must be capped.

Settings: 0 = Run this function
Associated functions: Command PBC must be set to 2

Note:

- This function requires that no light reaches the image sensors. The lens must therefore be covered by a lens cap, or put the F-mount protective cover on the camera, when executing this function.
- As the black level is influenced by the exposure time (especially for long exposure times at slow scan rates) it is recommended to perform the pixel black correction at the exposure time and line rate at which the camera will be operated.

7.24 Command PBS - Request Status After Pixel Black Correction

This command returns the status of the pixel black correction, with the following parameters:

0=Not completed yet
1=Succeeded
2=Error1: Image too bright
3=Error2: Image too dark
4=Error3: Timeout occurred

7.25 Command PER,PEG,PEB and PEIR - Programmable Exposure for R,G,B,and NIR

This command allows individual setting of the exposure time for each channel. It is only valid for the Shutter-Select mode

Settings: 800(9.52 μ s) to 1259549(14.99ms) in 11.9 ns steps
Associated functions: EI =0 :OFF (R,G,B and NIR independent)
EI=1: ON (R , B and NIR exposure interlocked with G)
Applicable modes: Shutter-Select (internal/external trigger)

7.26 Command PGC - Select pixel gain correction mode

This command enables (or disables) the “pixel gain” (flat-field) correction function, which compensates for Pixel Response Non Uniformity (PRNU) for individual pixels. The algorithm for compensation is different in No-shutter mode and Shutter-Select mode. If the operating mode is changed, an adjustment in the selected mode must be made. The factory default is Shutter-Select mode.

Settings: 0=Off (Default)
1=Factory Setting

Associated functions: 2=User area
Command PGR
Applicable modes: All

7.27 Command PGR - Pixel Gain Correction and Store in User Area

This command initiates the pixel gain correction function, and stores the settings in the user area.

Settings: 0= activate automatic process
Associated functions: Command PGC must be set to 2

Note:

- The image sensors must not be saturated when executing this function.
- When executing this function, the exposure time and line rate should be the same as when the camera is operated in the application.

7.28 Command PGS - Request Status After Pixel Gain Correction

This command returns the status of the pixel gain correction, with the following parameters:

0=Not completed yet
1=Succeeded
2=Error1: Image too bright
3=Error2: Image too dark
4=Error3: Timeout occurred

7.29 Command SCB - Select cable

This command sets if the length of a Camera Link cable to be used is changed.

Settings: 0= 1 to 5m
1= 5 to 10m
2= 10 to 15m

Note: the above lengths are if a standard type Camera Link cable is used.

7.30 Command SDC - Select Shading Correction Mode

This function enables (or disables) shading correction.

Settings: 0 = off (Bypass) (Default)
1 = Factory setting
2 = User area
Associated functions: Commands PGR, SDR and SDS

7.31 Command SDR - Run Shading Correction and store to user area

This function initiates automatic shading correction, and stores the result to the user area. This function should be used together with the flat-field correction (commands PGC and PGR). There are two types of shading correction: Individual R, G and B channel correction and chromatic shading correction.

Run Flat shading correction (SDR=0)

Run Color shading correction (SDR=1)

7.32 Command SDS - Request Status After Executing Shading Correction Command

This command returns the status of the shading correction function, with the following parameters:

0=Not completed yet
1=Succeeded
2=Error1: Image too bright
3=Error2: Image too dark
4=Error3: Timeout occurred

7.33 Command SRO - Sensor Read Out

This command selects the readout format from the sensor.

Settings: 0= OFF (Full Frame)
 1= Sub-sampling
 2= Windowing

7.34 Command SGR, SGG, SGB, SGIR - Sensor Gain Set R, G, B and NIR

This command sets the reference gain for gain control.

Settings: 0= Low Gain
 1= High Gain
 Common for all channels

7.35 Command TG - Trigger Origin

Selects whether an external signal or an internal clock generator is used as a trigger source.

Settings: 0=Internal clock generator
 1=External signal
Associated commands: TI
 TP

7.36 Command TI - Trigger Input

Selects whether the External Trigger input signal is taken from the Camera Link connector, or from the 12-pin connector. The 12-pin connector trigger input can be terminated by a 75 ohm terminator. This is selected by a rear panel DIP-switch (SW1).

Settings: 0=Camera Link connector
 1=12-pin connector

7.37 Command TP - Trigger Polarity

Settings: 0=Active Low (factory default)
 1=Active High

7.38 Command TR - Trigger Mode

Selects the trigger mode of the camera. Depending on the mode used, it allows the scan rate to either be programmed by an internal timing generator or by and external trigger pulse. See chapter 6 for details on the operation modes.

Settings: 0=No-shutter mode
 1=Shutter-Select mode
 2=Pulse Width Control (PWC) mode
Associated functions: Command TG (trigger origin)
 Command TI (trigger input)
 Command TP (trigger polarity)

7.39 Command TS - Test Pattern

This allows the camera to output a number of test patterns for set-up and troubleshooting.

Settings: 0=off
 1=Color bar
 2=Gray wedge
 3=Gray bars
 4=White (890LSB)

7.40 Command WB - White Balance

The white balance function can be used for manual setting, one-push automatic white balance (AWB) and fixed color temperatures (3 selections)

Settings: 0=Manual / On-Push AWB
 1=4000K
 2=4600K
 3=5600K
Applicable modes: All
Associated functions: Command AW (Gain)
 Command AH (Shutter)
 Command GAR - Gain Level red channel
 Command GAB - Gain Level blue channel

LQ-201CL

8. Serial communication and command list

8.1. Serial communication

The LQ-201CL can communicate by serial communication via the Camera Link connector or via RS232C in the 12-pin Hirose connector. The Baud Rate is fixed at 9600 bps. Switch SW1 at the rear panel of the camera is used to select which way the serial communication is set up.

SW1

No	Function	Setting	
		ON	OFF (Default)
1	Select serial communication path	12-Pin	Camera link
2	External trigger input termination	75 ohm	TTL

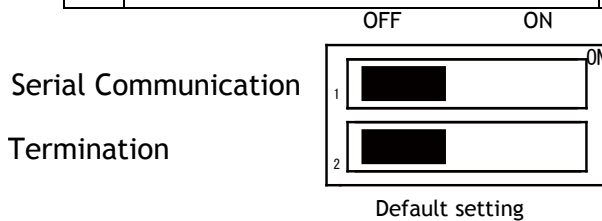

Note: HIROSE 12-Pin and Camera Link cannot be used simultaneously.

Communication setting:

Baud Rate	9600
Data Length	8bit
Start Bit	1bit
Stop Bit	1bit
Parity	Non
Xon/Xoff Control	Non

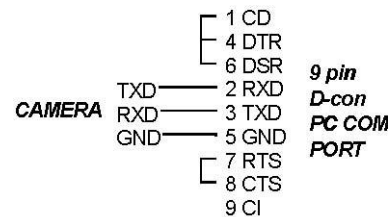

Protocol.

Transmit the setting command to camera:

NN is any kind of the commands.

NN=[Param.]<CR><LF>

e.g.

Send to camera: TR=0 <CR><LF>

Camera response: COMPLETE<CR><LF>

When the camera receives a valid command, camera will return 'COMPLETE'.

If the camera receives an invalid command, camera will return following:

e.g.

Send to camera: TRX=0 <CR><LF>

Camera response: 01 Unknown Command!!<CR><LF>

e.g.

Send to camera: TR=99 <CR><LF>

Camera response: 02 Bad Parameters!!<CR><LF>

Transmit the request command to camera:

The status of the camera's settings can be queried by transmitting NN?<CR><LF>, where NN is any one of the commands.

The camera will return the current setting data.

e.g.

Send to camera: TR? <CR><LF>

Camera response: TR=3<CR><LF>

8.2. Command list

	Command Name	Format	Parameter	Remarks
A - General settings and useful commands.				
EB	Echo Back	EB=[Param.]<CR><LF> EB?<CR><LF>	0=Echo off, 1=Echo on	Returns character sent to the camera. Off at power up
ST	Camera Status Request	ST?<CR><LF>		Display current settings of all functions
HP	Online Help Request	HP?<CR><LF>		Get a list of available commands
VN	Firmware Program Version Request	VN?<CR><LF>		3 digits Example: 100 = Version 1.00
PV	FPGA Program Version Request	PV?<CR><LF>		3 digits Example: 100 = Version 1.00
ID	Camera ID Request	ID?<CR><LF>		Returns the camera's ID (?). Factory setting.
MD	Model Name Request	MD?<CR><LF>		Returns the camera's model name. Factory setting.
UD	User ID	UD=[Param.]<CR><LF> UD?<CR><LF>		User definable field. Up to 16 characters.
B - Line Rate, Exposure				
LR	Line Rate	LR=[Param.]<CR><LF> LR?<CR><LF>	Full resolution 2544 to 1260000 clocks Sub-sampling/Windowing 1520 to 1260000 clocks - 1 clock is 11.9 ns	Only valid for TG=0
AR	One-push auto line rate set	AR=[Param.]<CR><LF> AR?<CR><LF>	0=Activate one-push auto line rate set	Only valid for TG=0
AL	Auto line rate reference level	AL=[Param.]<CR><LF> AL?<CR><LF>	0 to 1023	At 10-bit
EI	R/B/NIR Exposure interlocked with G	EI=[Param.]<CR><LF> EI?<CR><LF>	0=Off (independent) 1=On (interlocked)	Only valid for TR=1

LQ-201CL

PER	Programmable Exposure - Red	PER=[Param.]<CR><LF> > PER?<CR><LF>	Full resolution Sub-sampling/Windowing 800 to 1259549 clocks - 1 clock is 11.9 ns	Only valid for TR=1
PEG	Programmable Exposure - Green	PEG=[Param.]<CR><LF> > PEG?<CR><LF>	Full resolution Sub-sampling/Windowing 800 to 1259549 clocks - 1 clock is 11.9 ns	Only valid for TR=1
PEB	Programmable Exposure - Blue	PEB=[Param.]<CR><LF> > PEB?<CR><LF>	Full resolution Sub-sampling/Windowing 800 to 1259549 clocks - 1 clock is 11.9 ns	Only valid for TR=1
PEIR	Programmable Exposure - NIR	PEIR=[Param.]<CR><LF> > PEIR?<CR><LF>	Full resolution Sub-sampling/Windowing 800 to 1259549 clocks - 1 clock is 11.9 ns	Only valid for TR=1
AH	One-push AWB shutter	AH=[Param.]<CR><LF>	0=Activate one-push AWB shutter	Only valid for TR=1
AHRS	Inquire the status after one-push AWB shutter	AHRS?<CR><LF>	<One of following values will be replied from the camera> 0=AWB has not been finished yet. 1=Succeeded. 2=Error1 - G image was too bright. 3=Error2 - G image was too dark. 4=Error3 - Timeout-error occurred.	
C - Trigger mode				
TR	Trigger Mode	TR=[Param.]<CR><LF> TR?<CR><LF>	0=No-shutter mode 1=Shutter-Select mode 2=Pulse Width Control mode	
TG	Trigger Origin	TG=[Param.]<CR><LF> TG?<CR><LF>	0=Internal 1=External	TG=0 is available when TR=0 or TR=1
TI	Trigger Input	TI=[Param.]<CR><LF> TI?<CR><LF>	0=Camera-Link 1=12pin	
TP	Trigger Polarity	TP=[Param.]<CR><LF> TP?<CR><LF>	0=Active-Low 1=Active-High	
ARST	Auto reset mode	ARST=[Param.]<CR><LF> ARST?<CR><LF>	0=OFF 1=Auto Reset 2=Auto Interval	
D - Image format				
BI	Binning	BI=[Param.]<CR><LF> BI?<CR><LF>	0=Binning Off, 1=Binning On	
BA	Bit allocation	BA=[Param.]<CR><LF> BA?<CR><LF>	0=24bit, 1=30bit	
TS	Test Pattern	TS=[Param.]<CR><LF> TS?<CR><LF>	0=Off 1=Color Bar 2=Gray Pattern 1 3=Gray Pattern 2 4=White	Off at power up

LQ-201CL

SRO	Sensor read out	SRO = [Param.] <CR><LF> SRO ? <CR><LF>	0=off 1=Sub-sampling 2=Windowing	
E - Gain, white balance and signal settings				
GA	Gain Level - Master	GA=[Param.]<CR><LF> GA?<CR><LF>	Master Tracking Mode 0 to 802 Individual -402 to 1404	
GAR	Gain Level - Red	GAR=[Param.]<CR><LF> GAR?<CR><LF>	Master Tracking Mode -402 to 602 Individual -402 to 1404	
GAB	Gain Level - Blue	GAB=[Param.]<CR><LF> GAB?<CR><LF>	Master Tracking Mode -402 to 602 Individual -402 to 1404	
GAIR	Gain Level - NIR	GAIR=[Param.]<CR><LF> GAIR?<CR><LF>	Master Tracking Mode -402 to 602 Individual -402 to 1404	
GM	Gain mode	GM=[Param.]<CR><LF> GM?<CR><LF>	0=Master tracking 1=Individual	Default is 0
SGR	Sensor Gain Set Red	SGR=[Param.]<CR><LF> SGR?<CR><LF>	0=Low Gain 1=High Gain	
SGG	Sensor Gain Set Green	SGG=[Param.]<CR><LF> SGG?<CR><LF>	0=Low Gain 1=High Gain	
SGB	Sensor Gain Set Blue	SGB=[Param.]<CR><LF> SGB?<CR><LF>	0=Low Gain 1=High Gain	
SGIR	Sensor Gain Set NIR	SGIR=[Param.]<CR><LF> SGIR?<CR><LF>	0=Low Gain 1=High Gain	
BL	Black Level - Master	BL=[Param.]<CR><LF> BL?<CR><LF>	Master Tracking 0 to 64 Individual 0 to 64	
BLR	Black Level - Red	BLR=[Param.]<CR><LF> BLR?<CR><LF>	Master Tracking -64 to 63 Individual 0 to 64	
BLB	Black Level - Blue	BLB=[Param.]<CR><LF> BLB?<CR><LF>	Master Tracking -64 to 63 Individual 0 to 64	
BLIR	Black Level - NIR	BLIR=[Param.]<CR><LF> BLIR?<CR><LF>	Master Tracking -64 to 63 Individual 0 to 64	
BLM	Black Level mode	BLM=[Param.]<CR><LF> BLM?<CR><LF>	0=Master Tracking 1=Individual	Default is 0
WB	White Balance	WB=[Param.]<CR><LF> WB?<CR><LF>	0=Manual/One push AWB 1=4000K 2=4600K 3=5600K	
AW	Activate One-push AWB	AW=[Param.]<CR><LF>	0=Activate one-push AWB	
AWRS	Inquire the status after one-push AWB	AWRS?<CR><LF>	<Camera replies > 0=AWB has not been finished yet. 1=Succeeded. 2=Error1. Green image was	

LQ-201CL

			too bright. 3=Error2. Green image was too dark. 4=Error3. Timeout-error occurred.	
NR	Noise reduction	NR=[Param.]<CR><LF> NR?	0 = OFF, 1= ON	
F - Shading correction, pixel gain and pixel black correction				
SDC	Select shading correction mode	SDC=[Param.]<CR><LF> SDC?<CR><LF>	0=Off (Bypass) 1=Factory area 2=User area	
SDR	Run shading correction, store to user area	SDR=[Param.]<CR><LF>	0=Run flat shading correction, store to user area 1=Run color shading correction, store to user area	Store in user setting.
SDS	Inquire the status after shading correction	SDS?<CR><LF>	0=Shading correction not yet completed. 1=Succeeded. 2=Error 1 - Image too bright 3=Error 2 - Image too dark 4=Error 3 - Timeout error occurred.	
PGC	Select pixel gain correction mode	PGC=[Param.]<CR><LF> PGC?<CR><LF>	0=Off (Bypass) 1=Factory area 2=User area	Only valid for SHC=0.
PGR	Run pixel gain correction, store to user area	PGR=[Param.]<CR><LF> PGR?<CR><LF>	0=Run pixel gain correction, store to user area	Store in user setting.
PGS	Inquire the status after pixel gain correction	PGS?<CR><LF>	0=Pixel gain correction not yet completed. 1=Succeeded 2=Error 1 - Image too bright 3=Error 2 - Image too dark 4=Error 3 - Timeout error occurred.	
PBC	Select pixel black correction mode	PBC=[Param.]<CR><LF> PBC?<CR><LF>	0=Off (Bypass) 1=Factory area 2=User area	
PBR	Run pixel black correction, store to user area	PBR=[Param.]<CR><LF> PBR?<CR><LF>	0=Run pixel black correction, store to user area	Store in user setting.

LQ-201CL

PBS	Inquire the status after pixel black correction	PBS?<CR><LF>	0=Pixel black correction has not been finished yet. 1=Succeeded. 2=Error1 - Timeout error occurred.	
SCB	Select Cable	SCB=[Param.]<CR><LF> SCB?<CR><LF>	0 to 2	0 : 1~5m 1 : 5~10m 2 : 10~15m
MAVCG	Chromatic aberration Select	MAVCG=[Param1]<CR><LF> MAVCG?<CR><LF>	0=User1 Lens 1=User2 Lens 2=User3 Lens	Available when MAV=1
CABR	Chromatic aberration Red	CABR=[Param.]<CR><LF> CABR?<CR><LF>	-32768 to 32768	112 times writing make all parameters to be written. 112 times reading make all parameters to be read.
CABB	Chromatic aberration Blue	CABB=[Param.]<CR><LF> CABB?<CR><LF>	-32768 to 32768	112 times writing make all parameters to be written. 112 times reading make all parameters to be read.
CABIR	Chromatic aberration INR	CABIR=[Param.]<CR><LF> CABIR?<CR><LF>	-32768 to 32768	112 times writing make all parameters to be written. 112 times reading make all parameters to be read.
MAV	Chromatic aberration Control	MAV=[Param.]<CR><LF> MAV?<CR><LF>	0=OFF, 1=ON	
CABN1	Chromatic aberration Input Name 1	CABN1=[Param.]<CR><LF> CABN1?<CR><LF>	User1 Lens Data Name e.g. BV28mmLens	Lens Data Name is 16 characters.
CABN2	Chromatic aberration Input Name 2	CABN2=[Param.]<CR><LF> CABN2?<CR><LF>	User2 Lens Data Name e.g. BV28mmLens	Lens Data Name is 16 characters.
CABN3	Chromatic aberration Input Name 3	CABN3=[Param.]<CR><LF> CABN3?<CR><LF>	User3 Lens Data Name e.g. BV28mmLens	Lens Data Name is 16 characters.
CABLR	Chromatic aberration Left Side Pixel Red	CABLR=[Param1],[Param2]<CR><LF> CABLR?[Param1]<CR><LF>	Param1:User No. 0 to 2 Param2:-3,-2,-1,1,2,3	Param1 : Correspond to the value set in MAVCG
CABL B	Chromatic aberration Left Side Pixel Blue	CABL B=[Param1],[Param2]<CR><LF> CABL B?[Param1]<CR><LF>	Param1:User No. 0 to 2 Param2:-3,-2,-1,1,2,3	Param1 : Correspond to the value set in MAVCG
CABLIR	Chromatic aberration Left Side Pixel NIR	CABLIR=[Param1],[Param2]<CR><LF> CABLIR?[Param1]<CR><LF>	Param1:User No. 0 to 2 Param2:-3,-2,-1,1,2,3	Param1 : Correspond to the value set in MAVCG
CABAR	Chromatic aberration Area No. Red	CABAR=[Param1],[Param2]<CR><LF> CABAR?[Param1]<CR><LF>	Param1:User No. 0 to 2 Param2:1 to 8	Param1 : Correspond to the value set in MAVCG
CABA	Chromatic	CABAB=[Param1],[Param2]<CR><LF> CABAB?<CR><LF>	Param1:User No. 0 to 2	Param1 : Correspond to

LQ-201CL

B	aberration Area No. Blue	2]<CR><LF> CABAB?[Param1]<CR><LF>	Param2:1 to 8	the value set in MAVCG
VABAI R	Chromatic aberration Area No. NIR	CABAIR=[Param1],[Param2]<CR><LF> CABAIR?[Param1]<CR><LF>	Param1:User No. 0 to 2 Param2:1 to 8	Param1 : Correspond to the value set in MAVCG
CABSR R	Chromatic aberration 2 nd Pixel Red	CABSR=[Param1],[Param2]<CR><LF> CABSR?[Param1]<CR><LF>	Param1:User No. 0 to 2 Param2:1 to 7	Param1 : Correspond to the value set in MAVCG
CABSB B	Chromatic aberration 2 nd Pixel Blue	CABSB=[Param1],[Param2]<CR><LF> CABSB?[Param1]<CR><LF>	Param1:User No. 0 to 2 Param2:1 to 7	Param1 : Correspond to the value set in MAVCG
CABSI R	Chromatic aberration 2 nd Pixel NIR	CABSI=[Param1],[Param2]<CR><LF> CABSI?[Param1]<CR><LF>	Param1:User No. 0 to 2 Param2:1 to 7	Param1 : Correspond to the value set in MAVCG
VABTR R	Chromatic aberration 3 rd Pixel Red	CABTR=[Param1],[Param2]<CR><LF> CABTR?[Param1]<CR><LF>	Param1:User No. 0 to 2 Param2:1 to 6	Param1 : Correspond to the value set in MAVCG
CABTB B	Chromatic aberration 3 rd Pixel Blue	CABTB=[Param1],[Param2]<CR><LF> CABTB?[Param1]<CR><LF>	Param1:User No. 0 to 2 Param2:1 to 6	Param1 : Correspond to the value set in MAVCG
VABTI R	Chromatic aberration 3 rd Pixel NIR	CABTI=[Param1],[Param2]<CR><LF> CABTI?[Param1]<CR><LF>	Param1:User No. 0 to 2 Param2:1 to 6	Param1 : Correspond to the value set in MAVCG
HPFC	HPF_CTRL	HPFC=[Param.]<CR><LF> HPFC?<CR><LF>	0=off 1=on	Aperture Correction
G - Saving and loading data in EEPROM				
LD	Load Settings (from Camera EEPROM)	LD=[Param.]<CR><LF>	0=Factory area 1=User area1 2=User area2	Latest used DATA AREA will become default at next power up.
SA	Save Settings (to Camera EEPROM)	SA=[Param.]<CR><LF>	1=User area1 2=User area2 Note the parameter 0 is not allowed.	
EA	EEPROM Current Area No. Request.	EA?<CR><LF>	0=Factory area 1=User area1 2=User area2	The camera returns latest used DATA AREA.

Note: To avoid malfunction, do not attempt writing commands not shown in the above list.

9. Camera Control Tool for LQ-201CL

From www.jai.com Camera Control Tool for Windows XP/Vista/7 can be downloaded.

9.1. Software Install

Execute LQ-X01CL_Ver.XXX.exe in the downloaded file. The setup program starts and continues according to the screen instructions.

9.2. Open the Control Tool

Connect the camera to the PC on which the software is installed and set the power ON. Then select “All programs” in the Windows start menu, select “JAI A-S” and click “LQ-X01CL control tool”. LQ-X01CL Camera Control Tool and Communication windows will open.

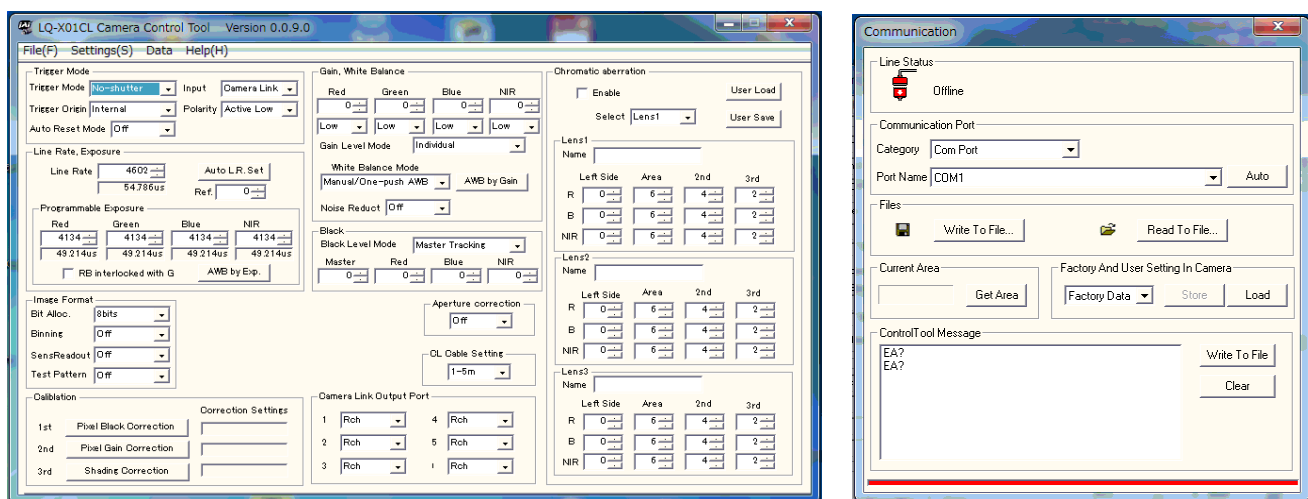

If the Communication window does not open, click “Help” in the Download menu of “Camera Control Tool” and click “Communication”.

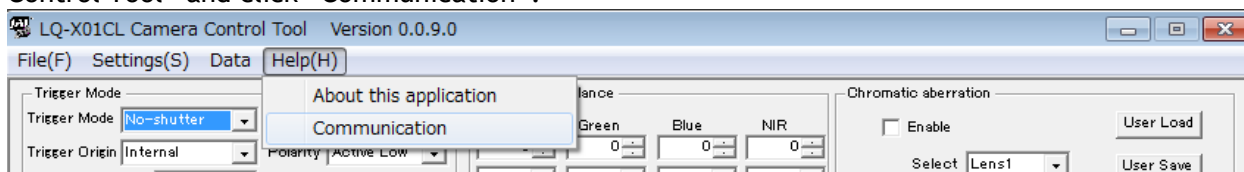

9.3. Connect a camera

If the frame grabber board is already installed in the connected PC, it will appear in the “Category” box in the “Communication port” pane. Click it if it is the appropriate one.

If the frame grabber board is not used, select the COM port to which the camera is connected, and click “OK”. After the connection is established, the RED Off-line icon changes to GREEN and the RED bar in the bottom changes to GREEN.



LQ-201CL

9.4. Camera control window

When the connection between camera and PC is completed, the camera control tool shows the current camera settings.

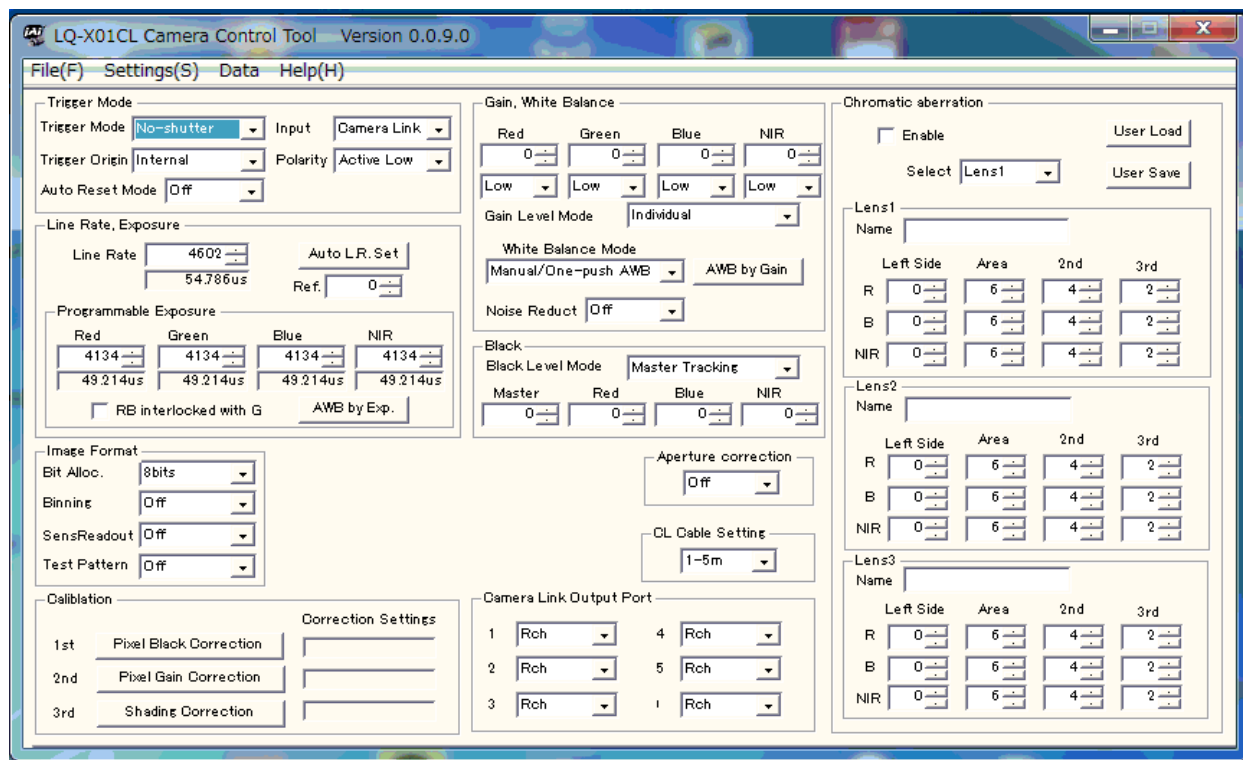

9.5 Menus

9.5.1 File menu

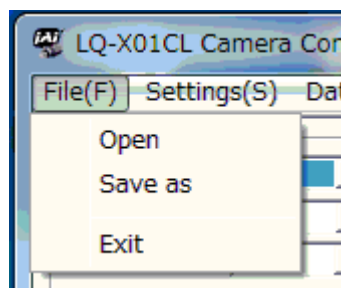

- Open: Transfer the setting parameters in HDD or other memory devices to the camera. The extension is .cam
- Save as: Store the setting parameters in HDD or other memory devices. The extension is .cam.
- Exit: Close the software.

9.5.2 Settings menu

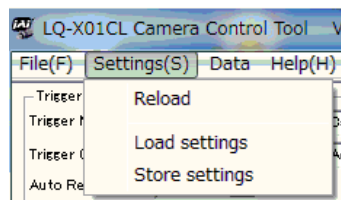

- Reload: Read the setting parameters from RAM area of the camera.
- Load settings: Read the setting parameters from EEPROM area of the camera. Select from Factory, User 1 or User2.
- Store settings: Read the parameters in the EEPROM area of the camera. Select from User 1 or User 2.

9.5.3 Line Correction menu

The following windows are for Pixel Black, Pixel Gain and Shading adjustments.

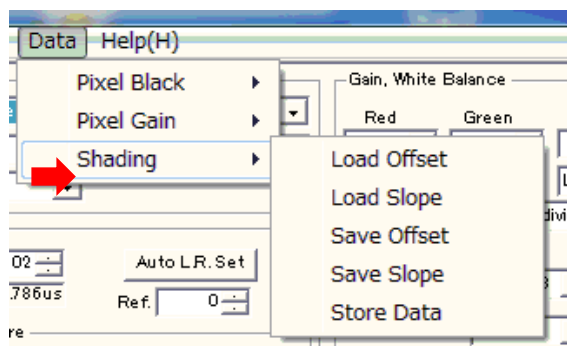
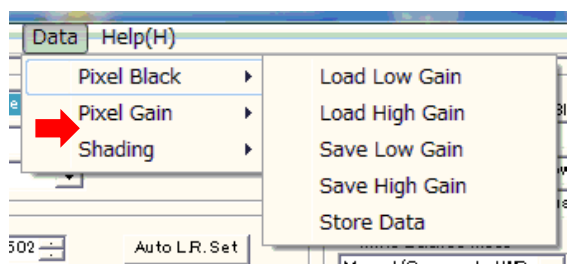
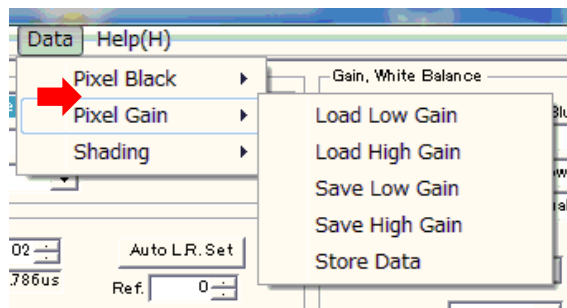

9.5.4 Help menu

Display camera software version, model name, firmware version and camera ID.

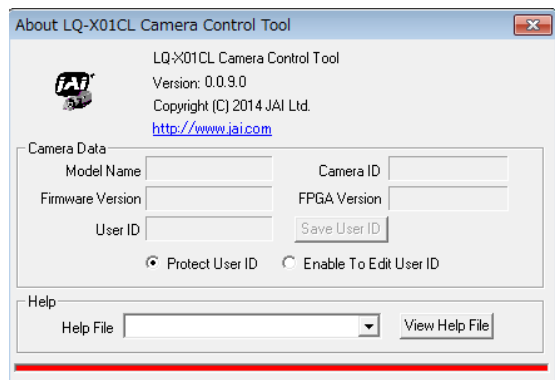

LQ-201CL

10. External appearance and Dimensions

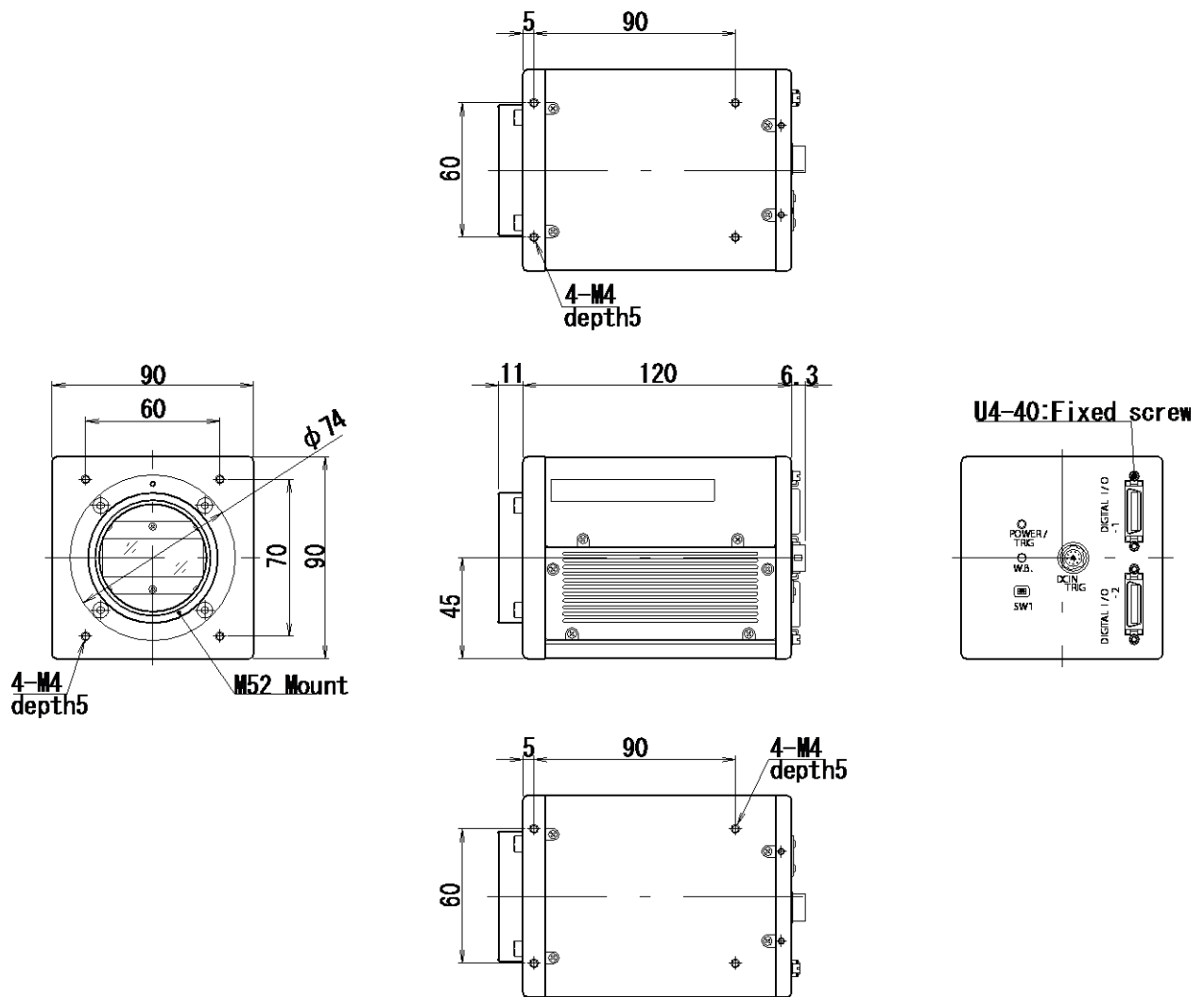

Outside dimensions tolerance: $\pm 0.3\text{mm}$

Fig.49 External Appearance and Dimensions (M52 mount)

LQ-201CL

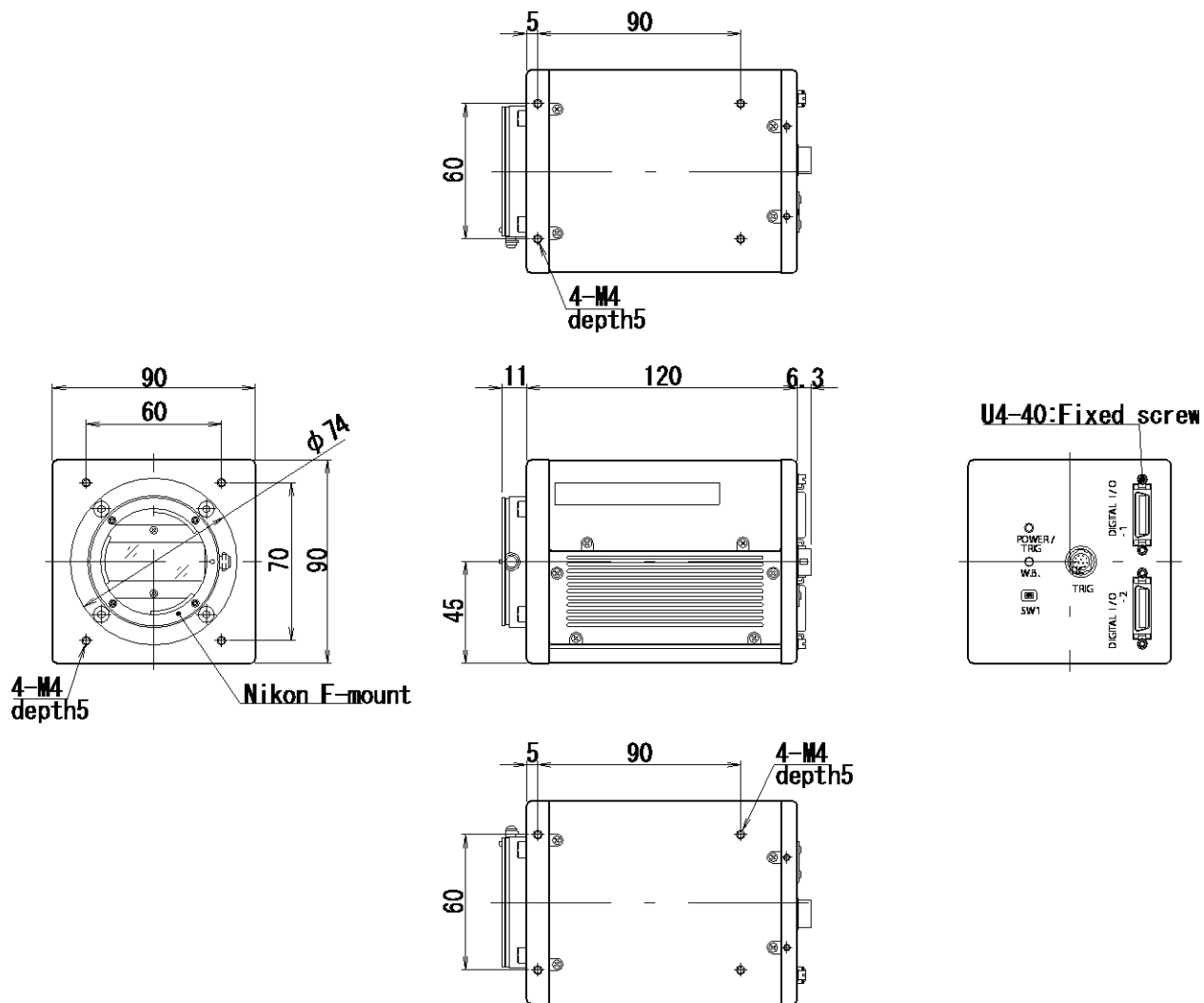

Outside dimensions tolerance: $\pm 0.3\text{mm}$

Fig.50 External Appearance and Dimensions (F mount)

LQ-201CL

11. Specifications

11.1 Typical data

Scanning system		Line Scan
Image Sensor		Effective pixels : 2048 pixels Pixel Size : 14.0 μm \times 14.0 μm Effective image length : 28.672 mm
Pixel clock		84.00 MHz
Line Rate	Full resolution /Binning	Total number of pixels per line: 2544 clocks Line rate: 30.29 μs (No-shutter mode with internal trigger) Line Frequency: 33.02 kHz
	Sub-sampling /Windowing	Total number of pixels per line: 1520 clocks Line rate: 18.1 μs (No-shutter mode with internal trigger) Line Frequency: 55.26 kHz
Sensor sensitivity		64nJ/cm ²
Sensitivity (Standard)		RGB : 2800 Lx (7800K White LED light) Conditions: Line Rate=600 μs , Gain=0dB, Shutter=OFF, Lens iris=F2, 100% output NIR : 2.35 $\mu\text{W/cm}^2$ at 800nm
S/N		55 dB (Green channel, Gain=0dB)
Synchronization		Internal
Video output		Digital 8-Bit x 4 or 10-Bit x 4 (Camera Link) * Default setting: 8-bit * Built-in pre emphasis function makes 10m transmission possible
Gain range (Note1)		Mode select: Master mode : Adjust master level and match R,G,B and NIR Master(Green): 0dB to +8dB R/B/NIR : -4dB to +6dB Individual : Adjust each channel individually R/G/B/NIR : -4dB to +14dB * Default setting: Master mode
White balance		Adjustable range : 4000K to 9000K Standard color temperature : 7800K
Black level (User setup)		Mode select: Master mode : Adjust master level and match R,G,B and NIR Master(Green): 0 to 64 LSB(10-bit output) R/B/NIR : -64 to 63 LSB (10-bit output) Individual : Adjust each channel individually R/G/B/NIR : 0 to 64 LSB (10-bit output) * Default setting: Master mode 8-bit (8 LSB)
Line rate (Variable) (Note2)		Range : 30.29 μs (1L) to 15.0 ms (SensReadout is OFF) Adjustment increment : 11.9 ns (1clk) This mode is available for No-shutter internal trigger and Shutter-Select internal trigger modes.
Electronic shutter		Available for Shutter-Select mode Adjustable range : 9.52 μs to 14.99 ms Adjustment increments : 11.9 ns (1 clk)
Binning		Available (line rate is not increased)

LQ-201CL

Test pattern	0: Color Bar 1: Gray 1 2: Gray 2 3: White (890 LSB)
Signal processing circuit	<p>1. Pixel gain correction: Pixel Response Non Uniformity(PRNU), Dark Signal Non Uniformity(DSNU)</p> <p>2. Shading compensation : ON / OFF Visible: Flat shading compensation or Color shading compensation can be selected NIR: Flat shading compensation or color shading compensation (Adjust using G channel as the reference) can be selected</p> <p>3. Linear matrix : R,G,B color compensation, no compensation for NIR</p> <p>4. Noise reduction</p>
Operation mode	No-shutter, Shutter-Select, Pulse Width Control (PWC)
Trigger input (note3)	<p>12-Pin : 4.0±2.0Vp-p TTL or Camera Link : LVDS (CC1)</p> <p>Possible to change negative logic or positive logic</p> <p>Minimum trigger width (Through Camera Link) : External trigger: more than 500 ns, PWC : more than 2 μs</p>
Sync output (open termination)	<p>Camera Link LVAL, DVAL, EEN</p> <p>Hirose 12-Pin XEEN (negative logic) 4.0Vp-p (no termination)</p>
Communication interface (Note4)	<p>EIA-644: Camera CC1 or RS-232C: 12-Pin connector</p> <p>Baud rate : 9600 bps</p> <p>Interface is switched by SW1 located rear panel.</p>
Field update	Available
Power	<p>DC +12V to +24V±10% 700mA (internal trigger, line rate 58.85 μs, 0dB, lens covered, +12V input)</p> <p>Note: Use a power supply capable of providing more than 3A.</p>
Lens Mount	<p>M52 mount (Standard) or Nikon F-Mount(Optional)</p> <p>Maximum allowed rear protrusion on lenses: M52 Mount : 13mm Nikon F-Mount: 13 mm</p>
Flange back	<p>M52 Mount : 46.5mm Nikon F-Mount : 46.5mm</p> <p>Lenses without iris rings cannot be used.</p>
Optical axis	Center ±0.1 mm (max)
Operating temperature /humidity	- 5°C to +45°C / 20 to 80% (non-condensing)
Storage temperature /humidity	-25°C to +60°C, 20 to 80% (non-condensing)
Vibration	3G (20Hz to 200Hz XYZ direction)
Shock	50G
Regulation	<p>CISPR Pub.22 (EN55022) CISPR Pub.24 FCC Part15 Class B IEC61000-4-2 conforming to Level 4(Contact discharge:8 kV, Air discharge:15 kV)</p>

LQ-201CL

Dimensions	90(W) x 90(H) x 120(D) mm (without connector and lens mount protrusion)
Weight	1050 g
Connectors	Camera Link : 10226-1A10PL x2 Hirose 12-Pin : HR10A-10R-12PB or equivalent

Note 1: If the digital output is set to 10-bit, the gain setting of more than 2dB may cause the Break in histogram.

Note 2: If the line rate becomes longer, the dark current will increase and as the result, the black level will be unstable.

Note 3: 12P input and Camera Link input cannot be used at the same time.

Note 4: 12P input and Camera Link input cannot be used at the same time.

Note 5: The mentioned specifications is guaranteed when the cable and connector to be used are ones JAI suggests.

Note 6: The above specifications are subject to change without notice.

11.2 Camera Spectral sensitivity

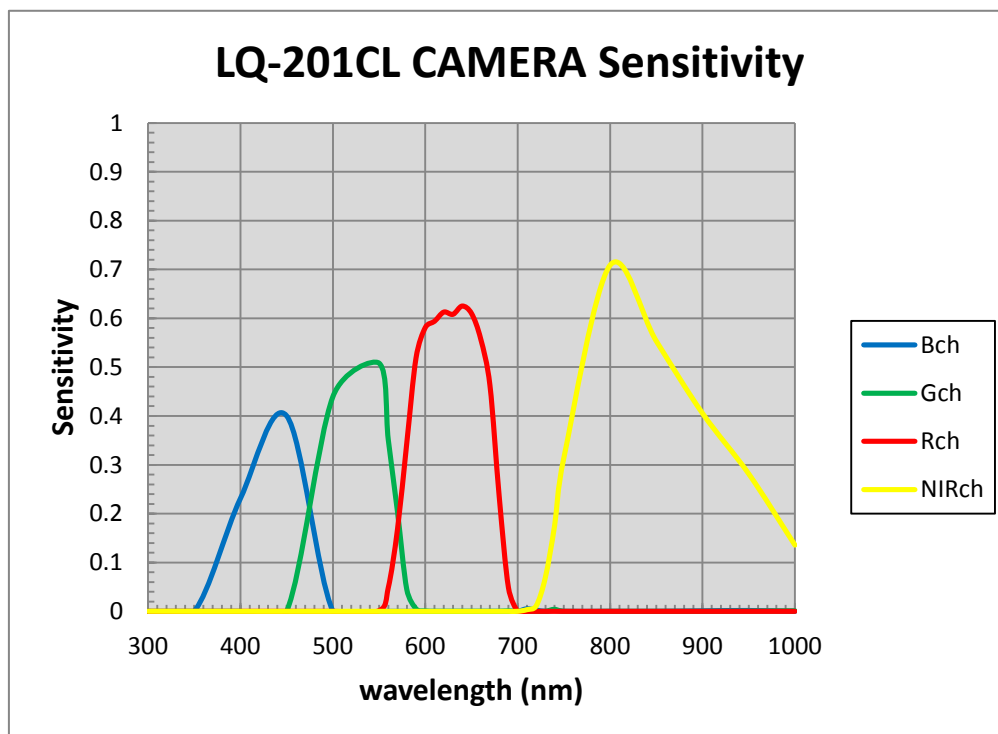

Fig. 27 Camera Spectral sensitivity

Appendix

1. Precautions

Personnel not trained in dealing with similar electronic devices should not service this camera. The camera contains components sensitive to electrostatic discharge. The handling of these devices should follow the requirements of electrostatic sensitive components.

Do not attempt to disassemble this camera.

Do not expose this camera to rain or moisture.

Do not face this camera towards the sun, extreme bright light or light reflecting objects.

When this camera is not in use, put the supplied lens cap on the lens mount.

Handle this camera with the maximum care.

Operate this camera only from the type of power source indicated on the camera.

Power off the camera during any modification, such as changes of jumper and switch settings.

2. Typical Sensor Characteristics

The following effects may be observed on the video monitor screen. They do not indicate any fault of the camera, but are associated with typical sensor characteristics.

V. Aliasing

When the CMOS camera captures stripes, straight lines or similar sharp patterns, jagged image on the monitor may appear.

Blemishes

All cameras are shipped without visible image sensor blemishes.

Over time some pixel defects can occur. This does not have a practical effect on the operation of the camera. These will show up as white spots (blemishes).

Exposure to cosmic rays can cause blemishes to appear on the image sensor. Please take care to avoid exposure to cosmic rays during transportation and storage. It is recommended using sea shipment instead of air flight in order to limit the influence of cosmic rays on the camera. Pixel defects/blemishes also may emerge due to prolonged operation at elevated ambient temperature, due to high gain setting, or during long time exposure. It is therefore recommended to operate the camera within its specifications.

Patterned Noise

When the sensor captures a dark object at high temperature or is used for long time integration, fixed pattern noise may appear on the video monitor screen.

3. Caution when mounting a lens on the camera

When mounting a lens on the camera dust particles in the air may settle on the surface of the lens or the image sensor of the camera. It is therefore important to keep the protective caps on the lens and on the camera until the lens is mounted. Point the lens mount of the camera downward to prevent dust particles from landing on the optical surfaces of the camera. This work should be done in a dust free environment. Do not touch any of the optical surfaces of the camera or the lens.

4. Caution when mounting the camera

When you mount the camera on your system, please make sure to use screws of the recommended length described in the following drawing. Longer screws may cause serious damage to the PCB inside the camera.

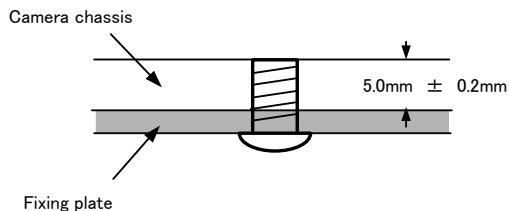

Mounting the camera to fixing plate

5. Exportation

When exporting this product, please follow the export regulation of your own country.

6. References

1. This manual and datasheet for the LQ-201CL can be downloaded from www.jai.com
2. Camera control software can be downloaded from www.jai.com

LQ-201CL

User's Record

Camera type: LQ-201CL
Revision:
Serial No.
Firmware version.

For camera revision history, please contact your local JAI distributor.

User's Mode Settings.

User's Modifications.

Company and product names mentioned in this manual are trademarks or registered trademarks of their respective owners. JAI A-S cannot be held responsible for any technical or typographical errors and reserves the right to make changes to products and documentation without prior notification.

Europe, Middle East & Africa

*Phone +45 4457 8888
Fax +45 4491 3252*

Asia Pacific

*Phone +81 45 440 0154
Fax +81 45 440 0166*

Americas

*Phone (toll-free) +1 800 445 5444
Phone +1 408 383 0300*

Visit our web site at www.jai.com



See the possibilities