

# CIS

**3G-SDI/HD-SDI  
FULL HD CMOS Color Camera**

# VCC-HD5

**Product Specifications  
& Operational Manual**

***(Preliminary)***

**CIS Corporation**

## Table of Contents

1.	Handling Precautions.....	1
1.1.	Camera Handling Precautions.....	1
1.2.	Restrictions on Applications.....	1
1.3.	Disclaimers (Exception Clause).....	1
2.	Product Outline.....	2
2.1.	Features.....	2
2.2.	Accessories.....	2
3.	Specifications.....	3
3.1.	General Specifications.....	3
3.2.	Part Names and Functions.....	5
3.3.	External Connector Pin Assignment.....	6
3.3.1	6pins Circular Connector.....	6
3.3.2	BNC.....	6
3.3.3	DC-IRIS Connector.....	6
3.3.4	φ3.5mm 4poles (RS-232C) Connector.....	6
4.	Camera Functions.....	7
4.1.	Genlock.....	7
4.2.	LTC (Longitudinal Time Code).....	7
4.3.	Defective Pixel Correction.....	8
4.3.1	Defective Pixel Data Type.....	8
4.3.2	Notes for Defective Pixel Correction.....	8
5.	Serial Communication.....	9
5.1.	Serial Communication Settings.....	9
5.1.1	Changing Speed of Serial Communication.....	10
5.2.	Command List.....	10
5.3.	Quick Reference Table.....	20
5.3.1	Quick Reference Table for Gain Settings.....	20
5.3.2	Quick Reference Table for Shutter Settings.....	21
6.	How to Operate the Camera with OSD Function.....	22
6.1.	How to Operate OSD Menu by Remote Controller.....	22
6.2.	Indication of OSD Menu.....	22
6.3.	OSD Menu Hierarchical Structure.....	23
7.	Dimensions.....	25
8.	Case for Indemnity (Limited Warranty).....	26
8.1.	Product Warranty.....	26
8.2.	CMOS Defective Pixels.....	26
8.3.	Product Support.....	26

## 1. Handling Precautions

### 1.1. Camera Handling Precautions

- Do not use or store the camera in dusty or humid places.
- Do not apply excessive force, vibration, or static electricity that could damage the camera. Please handle camera with care.
- Do not shoot direct images that are extremely bright (e.g., light source, sun, etc.) When extremely strong light source was shot, smear or blooming may occur. Put the lens cap on or protect the lens with seal when camera is not in use.
- Follow the instructions in Chapter 3.2. "Part Names and Functions" for connecting the camera module. Improper connection may cause damages not only to the camera module but also to the connected devices.
- Confirm mutual ground potential carefully before connecting camera to other equipment. Any AC leak from the connected devices may cause damages or destroy the camera.
- Do not apply excessive voltage. (Use only the specified voltage.) Unstable or improper power supply voltage may cause damages or malfunction of the camera module.
- Since VCC-HD5 is a highly dense camera module, please apply appropriate heat dissipation such as installing a metal base to the camera.

**Our warranty does not apply to damage or defects caused by neglecting the instructions and precautions explained in this manual.**

### 1.2. Restrictions on Applications

- The camera module must not be used for any nuclear equipment or aerospace equipment with which mechanical failure or malfunction could result in serious bodily injury or loss of human life.
- Do not use the camera under conditions or environments other than those specified in this manual.

### 1.3. Disclaimers (Exception Clause)

CIS should not be liable for any damages or losses if;

- damages or losses are caused by earthquake, lightning strike, fire, flood, or other acts of God.
- damages or losses are caused by deliberate or accidental misuse by the user, or failure to observe the information and instructions explained in this manual.
- damages or losses are caused by repair or modification conducted by the customer or any unauthorized party.

## 2. Product Outline

VCC-HD5 is a 3G-SDI interface, full HD color camera module using a 1/1.8" global shutter CMOS image sensor.

Features CIS proprietary ISP, Clairvu™ image processing engine, for superb imaging quality and high speed processing. Supports AE, auto white balance, color correction, edge enhancement, noise reduction, gamma, genlock, external sync, and other function. Complies with BT.709 and BT.2100 (HLG).

With its compact footprint, 29x29x55mm, VCC-HD5 is suitable for broadcasting, ROV, drone and vehicle, traffic surveillance, medical imaging, microscopy, and other life science equipment and systems.

### 2.1. Features

- CIS original Image Signal Processor, "Clairvu™" for superb imaging quality.
- Small footprint: 29mm × 29mm × 55mm (without projection)
- Corresponds to video output 1080 60p/59.94p/50p (3G-SDI), 1080 60i/59.94i/50i/30p/29.97p/25p/24p/23.98p (HD-SDI), 720 60p/59.94p/50p (HD-SDI).
- Genlock function (3-value analog signal or black burst)
- Supports RS-232C control.
- LTC (Longitudinal Time code)
- Supports OSD (On Screen Display) function via optional remote controller.

### 2.2. Accessories

- Standard Accessories
  - ◆ 6pins connector for power source
- Optional Accessory
  - ◆ RU-100 remote controller (OSD control, RS232C to USB conversion).

## 3. Specifications

## 3.1. General Specifications

Electrical Specifications		
Image sensor	Image sensor type	1/1.8" CMOS sensor SONY IMX265LQR
	Effective pixels	2064(H) × 1544(V)
	Unit cell size	3.45μm(H) × 3.45μm(V)
Resolution	1080p, 1080i:	1920(H) × 1080(V) 720p: 1280(H) × 720(V)
Aspect ratio		16 : 9
Video output format		1920 x 1080p @60fps (Level A) 3G-SDI 1920 x 1080p @60fps (Level B) 3G-SDI 1920 x 1080p @59.94fps (Level A) 3G-SDI 1920 x 1080p @59.94fps (Level B) 3G-SDI 1920 x 1080p @50fps (Level A) 3G-SDI 1920 x 1080p @50fps (Level B) 3G-SDI 1920 x 1080i @60fps HD-SDI 1920 x 1080i @59.94fps HD-SDI 1920 x 1080i @50fps HD-SDI 1920 x 1080p @30fps HD-SDI 1920 x 1080p @29.97fps HD-SDI 1920 x 1080p @25fps HD-SDI 1920 x 1080p @24fps HD-SDI 1920 x 1080p @23.97fps HD-SDI 1280 x 720p @60fps HD-SDI 1280 x 720p @59.94fps HD-SDI 1280 x 720p @50fps HD-SDI
Sync system		Internal sync. / External sync.
Video output standard		3G-SDI/HD-SDI : Y/Pb/Pr(4:2:2 10bit) BNC 75Ω terminal
Sensitivity		TBD 2000lx
Minimum illumination		F1.4 TBD lx Conditions: VIDEO 50%, AGC 36dB, electric shutter OFF
Gain variable range		AGC (Max. gain : 0dB~48dB) MANUAL: 0dB~48dB *Noise may be noticeable with high gain setting.
Shutter speed variable range		AUTO: 1/13600s~1/23.98s (Preferred setting) *Frame rate setting of output format limits the slowest shutter speed. MANUAL: 1/13600s~1/23.98s * Frame rate setting of output format limits the slowest shutter speed.
White balance adjustment		AUTO: Standard, Outdoor, Fluorescent MANUAL: Red Gain, Blue Gain, One Push PRESET: Custom (Color temperature settings), Tungsten(3200K), Daylight(5500K), Cloudy(6500K), Shade(8000K)
DC IRIS output		Auto/Open selectable. Can be used with electric shutter. (with priority to electric shutter)
Auto exposure detection		Average, Center-Weighted, Spot, Backlight Compensation
Flicker cancellation		ON, OFF: Power frequency 50Hz, 60Hz
Edge enhancement		OFF, 1~7
Color correction		Auto, Standard, Fluorescent Light, Tungsten Lamp
Saturation adjustment		0%(B/W)~100%(typ.)~200%
Cyan suppression adjustment		0~15
Color saturation suppression		OFF, 1~7

Noise reduction	OFF, 1~6	
Gamma (Contrast)	Complies with BT.709 curve (Contrast: -2, -1, 0, +1, +2) Complies with BT.2100 (HLG) curve	
Dynamic range	Low (for better SNR), Normal, High	
Knee point	OFF, 100%, 95%, 90%, 85%, 80%, 75%	
Color gamut	Complies with BT.709, BT.2020	
Master pedestal	-100 ~ 0 ~ +100	
Pedestal (R,G,B)	RGB independent: -100 ~ 0 ~ +100	
Color balance	RGB independent: 0 ~ 100 ~ 200	
Pixel defect correction (white spot)	Corrected upon shipment.	
LTC	OFF, ON Accepts external SMPTE Time code in the LTC IN terminal. (Supports resetting internal self-counting time code.)	
Camera preset settings	1, 2, 3, 4 (Four kinds of preset to store.)	
Remote control communications	Supports RS-232C communications via $\phi$ 3.5 plug (4poles) to control camera settings. Supports OSD function with connecting the optional remote controller, RU-100.	
Power requirements	DC+9~+15V	
Power consumption	Typ. TBD W / Max. TBD W	
<b>Mechanical Specifications</b>		
Dimensions	Refer to overall dimensional drawing	
Weight	Approx. 80g	
Lens mount	C mount ※Please refer to the drawing.	
<b>Environmental Specifications</b>		
Safety/Quality standards	UL: Conform to UL Standard CE: (To be applied for) EMC 2014/30/EU Emission: EN61000-6-3:2007+A1:2011 Immunity: EN61000-6-2:2005 RoHS 2011/65/EU (EU)2015/863, EN50581 (RoHS2) FCC Class A Digital Device (To be applied for) This device complies with Part 15 of the FCC Rules. Operation is subject to the following two conditions: (1) this device may not cause harmful interference, and (2) this device must accept any interference received, including interference that may cause undesired operation.	
Durability	Vibration	Acceleration: 98m/s <sup>2</sup> (10G)
		Frequency: 20 ~ 200Hz
		Direction: X, Y, and Z 3 directions
		Testing time: 120 minutes for each direction
Shock	Without packaging, no malfunction with 980m/s <sup>2</sup> (100G) for $\pm$ X, $\pm$ Y, and $\pm$ Z, 6 directions without packaging.	
Operational conditions		Operational temperature: -5 ~ +45°C Humidity: 20 ~ 80%RH with no condensation
Storage conditions		Storage temperature: -25 ~ +60°C Humidity: 20 ~ 80%RH with no condensation

[3G-SDI output Level A and Level B]

The difference between Level A and Level B is the way of mapping Y signal and Cb/Cr signal onto 3G-SDI standard signal. The difference does not affect the resolution of the video signal. Some 3G-SDI receivers correspond to either Level A or B, whereas other receivers correspond to both Levels, so please set the camera mode to match your 3G-SDI receiver.

## 3.2. Part Names and Functions

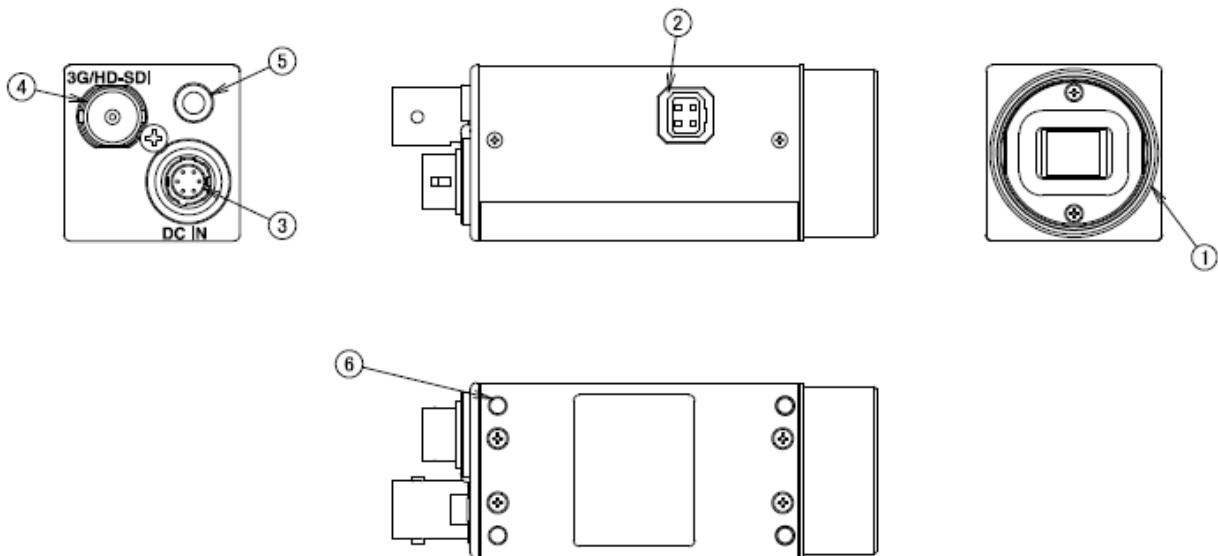

- ① C mount  
To mount a C mount lens. Screw length from the lens mount surface must be 6mm or less, and protrusion of the lens must be 8mm or less. When a lens is not mounted, put the lens cap on or put a seal to protect image sensor.
- ② DC-IRIS connector  
Connection terminal for DC-IRIS lens
- ③ Connector for power input, Genlock, and LTC signal input  
Please refer to the external connector pin assignment.
- ④ Video signal output  
With a BNC cable, connect to a 3G-SDI input monitor or HD-SDI input monitor.  
Please use BNC cable with high frequency characteristics correspond to 3G-SDI or HD-SDI.
- ⑤  $\phi 3.5(4 \text{ poles})$  connector (RS-232C)  
Connector for RS-232C signals.  
Please refer to the external connector pin assignment to connect.  
\*Do not connect to any audio equipment such as earphones and headsets.  
Connecting to such equipment may cause malfunction.
- ⑥ Screw holes for camera installation  
Screw holes to install camera.  
Please note that depth of the front screw holes and the rear screw holes are different.

### 3.3. External Connector Pin Assignment

#### 3.3.1 6pins Circular Connector

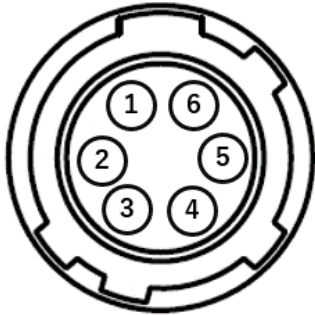

Model name: SNH-8-6(RPCB)  
(SamWoo Electronics)

Pin No.	Description
1	Power IN DC+12V
2	EXT SYNC IN
3	LTC IN
4	N.C.
5	GND
6	GND

#### 3.3.2 BNC

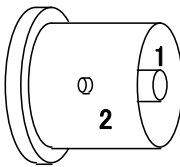

Model name: BNC(75)-PLR-PC(D)-12G-3  
(Hirose Electric Co., Ltd.)

Pin No.	Description
1	3G-SDI/HD-SDI output
2	GND

#### 3.3.3 DC-IRIS Connector

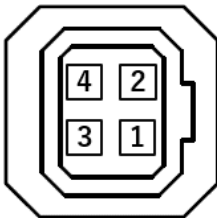

Model name: D4-157J-250 (Technical Electron. Co. LTD)

Pin No.	Description
1	DUMP-
2	DUMP+
3	DRIVE+
4	DRIVE-(GND)

#### 3.3.4 φ3.5mm 4poles (RS-232C) Connector

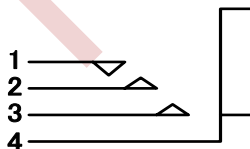

Model name: M03-A41A0 (Marushin Electric Mfg. Co., Ltd)

Pin No.	Description
1	Power(+5V) *For option
2	TXD(Camera)
3	RXD(Camera)
4	GND

Connection of φ3.5 (4 poles) connector (RS-232C)

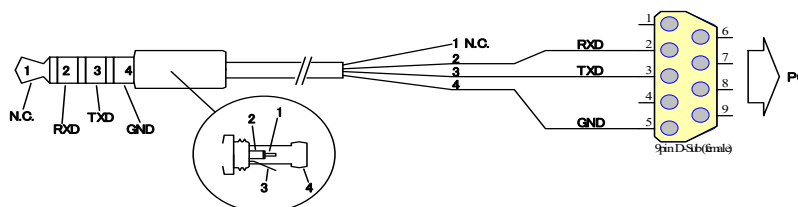



## 4. Camera Functions

### 4.1. Genlock

- Input analog external sync signals (black burst or 3-value SYNC) to the EXT SYNC IN terminal of 6pins connector to enable Genlock function.
- The corresponding external sync signals depend on its video output format, therefore, please refer to the chart below and input appropriate signals.

		EXT SYNC IN				
CAMERA FORMAT	1080p60A			1080i60	720p60	1080p30
	1080p59.9A	NTSC		1080i59.9	720p59.9	1080p29.9
	1080p50A		PAL	1080i50	720p50	1080p25
	1080p60B			1080i60	720p60	1080p30
	1080p59.9B	NTSC		1080i59.9	720p59.9	1080p29.9
	1080p50B		PAL	1080i50	720p50	1080p25
	1080i60			1080i60	720p60	1080p30
	1080i59.94	NTSC		1080i59.9	720p59.9	1080p29.9
	1080i50		PAL	1080i50	720p50	1080p25
	1080p30			1080i60	720p60	1080p30
	1080p29.9	NTSC		1080i59.9	720p59.9	1080p29.9
	1080p25		PAL	1080i50	720p50	1080p25
	1080p24					1080p24
	1080p23					1080p23.9
	720p60			1080i60	720p60	1080p30
	720p59.9	NTSC		1080i59.9	720p59.9	1080p29.9
	720p50		PAL	1080i50	720p50	1080p25

[Note]

- ◆ Input Black Burst signals for NTSC/PAL signals. Input 3-value SYNC signals for other than NTSC/PAL signals.
- ◆ EXT SYNC IN is terminated with 75Ω. (When camera power is OFF, mode becomes high impedance.)
- ◆ With inputting external signals specified in the chart above, the camera will automatically be in external sync mode.
- ◆ When there is no external signal, the camera will operate in internal sync mode.
- ◆ Disturbance images occur immediately after inputting external signals, however this is normal.
- ◆ With a signal other than those specified in the chart above to the EXT SYNC IN terminal, disturbance images may occur or there will be no image.

### 4.2. LTC (Longitudinal Time Code)

- Supports Time code insertion to 3G/HD SDI signals.
- Input LTC signals (time code) to the LTC IN terminal of the 6pins connector to insert external time code.

When there is no signal input to the LTC IN terminal, user can insert internal time code.

Internal time code starts with 00:00:00.00 when power is ON, and when signals are input to the LTC IN terminal, time code switches to the external time code. Under this condition, if no signal is input to the LTC IN terminal, internal time code starts with the set time code.

Signal Format: SMPTE Time code      Signal Level: 0.5 ~ 2[Vp-p]

### 4.3. Defective Pixel Correction

In addition to the corrected defective pixel data registered at factory, we provide a method to update the defective pixels data occurred after shipping out from our factory. User can acquire correction data for V Flip forward and V Flip backward separately which changes automatically according to V Flip setting. User can register defective pixels up to 128 points. Please refer to [Section 5.2, Command List](#) for details.

#### 4.3.1 Defective Pixel Data Type

There are two types of defective pixel data.

- Defective pixel data registered at factory  
These data cannot be over-written.
- Defective pixel data registered by user  
These data can be over-written.

#### 4.3.2 Notes for Defective Pixel Correction

- To save the data registered or deleted with defective pixels correction command (SU 200~203), execute SAVE command (SU 705).
- Init command (SU 700) does not restore defective pixel correction data. Use SU 203 to delete all data.
- Defective pixel correction data is not subject to Camera Setting Store/Load command (SU 100/101).
- Factory data and user-registered data cannot be the same. Therefore, if user detects the same defective points as factory data, this function ignores those points.
- If user specifies a pixel data with the same coordinates as factory setting, error will occur.
- Specify coordinates with standard 1920×1080 regardless of frame rate settings.
- Please note that the detected results may not always be the same due to temperature, noise, and other conditions.
- Inappropriate data registration of defective pixels may cause difficulties to acquire proper images.

Neglecting these instructions may cause not only incorrect pixel defect correction, but also failure of acquiring proper images.

## 5. Serial Communication

### 5.1. Serial Communication Settings

(1) Please refer to the chart below for serial communication settings.

Baud rate	9600bps (factory setting), 38400bps, 115200bps
Data	8bit
Stop bit	1bit
Parity	None
XON/XOFF	No control

(2) Control code

- Text-based communication executes camera control. Only ASCII 0x20~0x7E, 0x0A(LF=¥n), 0x0D(CR=¥r) must be used. Do not use other than these codes.
- By sending commands, parameters, and CR(0x0D) from host to camera, user can change camera settings and acquire camera-setting parameters. (LF can substitute for CR).
- There are two types of commands. One is SU command to send settings and instructions to the camera ("S" for "Set"), and the other is GU command ("G" for "Get") to obtain information from the camera.

Command	Parameter 1	Parameter 2	Function
GU	Address	Normally None (There are exceptions in some cases)	To acquire camera setting information.
SU	Address	Data (There may be more than one)	To change camera settings.

(3) How to set a command

- ">" must be output from the camera as a prompt.
- Commands are not case-sensitive.
- Separate between a command and a parameter by single space (0x20).
- From the head of the input character to the linefeed code (CR) is defined as a single serial command.
- Parameters start with 0x are regarded as hexadecimal, parameters start with 0b are regarded as binary, and others are regarded as decimal.
- Commands analyze parameters from the head to identifiable letters.
- Please refer to "[Section 5.2. Command List](#)" for details on address and data.
- Do not input values and letters other than those explained in the above and those mentioned in "[Section 5.2. Command List](#)".
- Camera receives the returned command from host, and echoes the command back. At this time, camera converts the linefeed code (CR) to CR LF and echoes the code back.

(4) Setting examples

【Example of GU command】

To get the information of the address 10

[Send] GU[sp]10[¥r]

[Returned value] GU[sp]10[¥r][¥n]

[Returned value] 50[¥r] [¥n]

[Returned value] [¥r] [¥n]

[Returned value] >[sp]

[Echo back]

[Acquired data + Linefeed]

[Linefeed]

[Prompt (> and space)]

[¥r]=CR(0x0D)

[¥n]=LF(0x0A)

[sp]=Space(0x20)

## 【Example of SU command】

To set 30 to the address 10

[Send] SU[sp]10[sp]30[¥r]

[Returned value] SU[sp]10[sp]30[¥r][¥n] [Echo back]

[Returned value] [¥r] [¥n] [Linefeed]

[Returned value] >[sp] [Prompt (> and space)]

## 5.1.1 Changing Speed of Serial Communication

Baud Rate command (SU 725) changes transfer rate of serial communication out of 9600bps, 38400bps, and 115200bps.

- The changes made are reflected after rebooting camera, not immediately after executing the command.
- Execute SAVE command (SU 705) to save the setting values.
- Baud rate command is not subject to Init command (SU 700) so that executing Init command does not restore settings.
- Baud rate command is not subject to Camera Setting Store/Load command (SU 100/101).
- Only when baud rate setting is 9600bps, user can use the optional remote controller RU-100.

## 5.2. Command List

**Video Format**

Function	Address	Set Value	Initial Value	Description
Video Format	1	0: 1080p 60fps (LevelA) 1: 1080p 59.94fps (LevelA) 2: 1080p 50fps (LevelA) 3: 1080p 60fps (LevelB) 4: 1080p 59.94fps (LevelB) 5: 1080p 50fps (LevelB) 6: 1080i 60fps 7: 1080i 59.94fps 8: 1080i 50fps 9: 1080p 30fps 10: 1080p 29.97fps 11: 1080p 25fps 12: 1080p 24fps 13: 1080p 23.98fps 14: 720p 60fps 15: 720p 59.94fps 16: 720p 50fps	6	This is to set video output format.

**AE related**

Function	Address	Set Value	Initial Value	Description
Gain Mode	2	0: Manual 1: Auto	1	This is to set gain control mode.
Gain Value	3	Magnification×0x10000 Setting range: 1~approx. x251 (0x10000~0xFB304B)	0x10000 (65536)	This is to set gain value when gain mode is Manual. (*1) e.g.) To set x2 (approx. 6dB): SU 3 0x00020000 ※ Please Refer to <a href="#">Section 5.3.1. Quick Reference Table for Gain Settings.</a>
Gain Max Value	4	Magnification×0x10000 Setting range: 1~approx. x251 (0x10000~0xFB304B)	0x400000 (4194304)	This is to set the max gain value when gain mode is Auto. (*1) ※ Please refer to <a href="#">Section 5.3.1. Quick Reference Table for Gain Settings.</a>
Shutter Mode	5	0: Manual 1: Auto	1	This is to set shutter control mode.
Shutter Value	6	Exposure time [s]×0x100000 Setting range: 1/13600~1/23.98s (0x4D~0xAAD6)	0x4444 (17476) 1/60s	This is to set shutter value (exposure time) when shutter mode is Manual. (*1) Shorter value than 1 frame length must be set. For example, when video format is 60fps, the maximum shutter value will be 0x4444 (1/60s). ※ Please refer to <a href="#">Section 5.3.2. Quick Reference Table for Shutter Settings.</a>
Shutter Limit	7	The 1 <sup>st</sup> Param: Max value Exposure time [s]×0x100000 Setting range: 1/13600~1/23.98s (0x4D~0xAAD6)	0x4444 (17476) 1/60s	This is to set shutter variable range when shutter mode is Auto. (*1) Shorter value than 1 frame length must be set. Max<Min is invalid. e.g.) To set Max=1/60s, Min=1/8000s: SU 7 0x4444 0x83 ※ Please refer to <a href="#">Section 5.3.2. Quick Reference Table for Shutter Settings.</a>
		The 2 <sup>nd</sup> Param: Min value Exposure time [s]×0x100000 Setting range: Same as Max value.	0x4D (77) 1/13600s	
Metering Mode	8	0: Average 1: Center-Weighted 2: Spot 3: Backlight Compensation	1	This is to set metering mode.
Spot Block	9	The 1 <sup>st</sup> Param: X value: 0~15	7	This is to set X, Y, W, and H values for Spot metering. X: Far left of metering field Block, X coordinate Y: Top of metering field Block, Y coordinate W: Width of metering field (number of block) H: Height of metering field (number of block) e.g.) Execute SU 9 6 7 4 2 to set 4x2 block from the coordinate (6, 7).
		The 2 <sup>nd</sup> Param: Y value: 0~15	7	
		The 3 <sup>rd</sup> Param: W value: 1~16	2	
		The 4 <sup>th</sup> Param: H value: 1~16	2	
AE Speed	10	0~15	10	This is to set AE convergence speed.
Exposure Compensation Value	11	0(-12dB)~12(0dB)~24(+12dB)/ per 1dB	12	This is to set exposure compensation value.

**AE related (continue)**

Function	Address	Set Value	Initial Value	Description
Flicker Cancel	12	0: Off 1: 50Hz power mode 2: 60Hz power mode	0	This is to set ON/OFF of flicker cancel. Select mode according to power frequency.
Gain Value, Plus Minus	13	-1: decrease 1dB 1 : increase 1dB	None	This is to change gain value by $\pm 1$ dB from the current setting. (*1) Valid when gain mode is Manual. (Dedicated to SU)
Shutter Speed, Plus Minus	14	-1: decrease 1step (1/4EV) 1 : increase 1step (1/4EV)	None	This is to change shutter speed by $\pm 1$ step (1/4EV) from the current value. When shutter speed decreases by 1step, shutter value becomes bigger (*1) Valid when shutter mode is Manual. (Dedicated to SU)
Current Gain	55	None	None	This is to acquire the current gain. (Dedicated to GU) (*1)
Current Shutter	56	None	None	This is to acquire the current shutter value. (Dedicated to GU) (*1)

(\*1) Due to physical limitation of the sensor and circuit, there are some cases that user cannot control gain, shutter values, and limits as designated by commands. User can check the actual values with Current Gain and Current Shutter commands.

**WB related**

Function	Address	Set Value	Initial Value	Description
WB Mode	20	0: Manual 1: Auto 2: Preset	1	This is to set White Balance (WB) mode.
WB Manual Memory	21	0~4	0	This is to choose the memory to store set values when WB Mode is Manual. Memory stores up to 5 types (0~4) of settings..
Manual Red Gain	22	100~1600(%)	164	This is to set Red Gain when WB Mode is Manual.
Manual Blue Gain	23	100~1600(%)	161	This is to set Blue Gain when WB Mode is Manual.
One Push Trigger	24	1: W×H 2: W/2×H/2 3: W/4×H/4	None	This is to execute One Push WB when WB mode is Manual. Choose a detection range with setting value. If execution of One Push WB is not processed properly because of the light shielding or other reasons, camera will return Run Time Error. (Dedicated to SU)
WB Auto Func	25	0: Standard 1: Outdoor 2: Fluorescent	0	This is to choose the environmental lighting condition when WB Mode is Auto.
WB Preset Func	26	0: Custom 1: Tungsten (3200K) 2: Daylight (5500K) 3: Cloudy (6500K) 4: Shade (8000K)	2	This is to choose the environmental lighting condition when WB Mode is Preset.
WB Preset Temp	27	2500~15000(K)	5500	This is to set color temperature when WB Preset Func is Custom.
WB LB Shift	28	-10~10	0	This is to set shift amount of WB gain toward black
WB CC Shift	29	-10~10	0	This is to set shift amount of WB gain toward green magenta.
Current Red Gain	58	None	None	This is to acquire the current Red Gain. (Dedicated to GU)
Current Blue Gain	59	None	None	This is to acquire the current Blue Gain. (Dedicated to GU)

**Image Quality related**

Function	Address	Set Value	Initial Value	Description
Detail	30	0: Off 1: (Low)~7(High)	2	This is to set the strength of edge enhancement.
Gamma	35	0: BT.709 -2 1: BT.709 -1 2: BT.709 3: BT.709 +1 4: BT.709 +2 5: HLG75	2	This is to set gamma type and contrast. 0~4 are the curves that comply with BT.709. Contrast changes in the range of -2 ~ +2. 5 is for HLG75 that means 75% output level is regarded as 100% input level.
Knee	36	0: Off 1: 100% 2: 95% 3: 90% 4: 85% 5: 80% 6: 75%	4	This is to set knee point. Valid except when Gamma is BT.709 and D-range is Low. Knee slope varies according to the selected maximum D-Range.
Master Pedestal	37	-100 ~+100	0	This is to set Master pedestal.
Red Pedestal	38	-100 ~+100	0	This is to set Red pedestal.
Green Pedestal	39	-100 ~ +100	0	This is to set Green pedestal.
Blue Pedestal	40	-100 ~ +100	0	This is to set Blue pedestal.
Red Balance	41	0~200	100	This is to set Red balance.
Green Balance	42	0~200	100	This is to set Green balance.
Blue Balance	43	0~200	100	This is to set Blue balance.
D-Range	44	0: Low Equivalent to 120% at BT.709 Invalid at HLG (Handled as Normal)  1: Normal Equivalent to 200% at BT.709 Equivalent to 600% at HLG  2: High 400% at BT.709 Equivalent to 1200% at HLG	1	This is to set Dynamic range. With Low, both D range and sensitivity decrease, but noise level becomes the lowest. (*2) With High, the minimum gain value will be limited to 0x20000. (Even if a lower value is set, gain value becomes 0x20000.)  ※ The D-range definition of BT.709 and HLG are different, ref. below.  [BT.709] 100% output level (without Knee) is regarded as 100% input level. [HLG] 50% output level is regarded as 100% input level.

(\*2) The initial setting of VCC—HD5 is Normal. When you are switching the model from VCC-H3N to VCC-HD5 and need the same setting as VCC-HD3N, set Dynamic range to Low.



**Image Quality related (continue)**

Function	Address	Set Value	Initial Value	Description
Color Saturation	45	0~200	100	This is to set color saturation.
Cyan Suppression	46	0~15	15	This is to set suppression for Cyan saturation.
Color Adjustment	47	The 1 <sup>st</sup> Parameter: Selection of color 0: Magenta 1: Red 2: Yellow 3: Green 4: Cyan 5: Blue	All 0	This is to set color adjustment values. There are three kinds of adjustment items for each 6 color, which makes it a total of 18 parameters for color adjustment.  e.g.) To set -3 to Cyan Hue SU 47 4 0 -3
		The 2 <sup>nd</sup> Parameter: Selection of item to adjust 0: Hue 1: Saturation 2: Depth		To execute GU, please specify the 1 <sup>st</sup> parameter and the 2 <sup>nd</sup> parameter.  e.g.) To acquire adjustment value of Cyan Hue GU 47 4 0
		The 3 <sup>rd</sup> Parameter: Adjustment value -20~20		
Noise Reduction	50	0: OFF 1: Level 1 (Low) 2: Level 2 ... 6: Level 6 (High)	0	This is to set the level of noise reduction.
Color Correction	52	0: Auto 1: Standard 2: Fluorescent Light 3: Tungsten Lamp	0	This is to set color correction.
Color Suppression	53	0: Off 1 (Low)~7(High)	0	This is to set color suppression.
Color Space	54	0: BT.709 1: BT.2020	0	This is to set color gamut.

**Lens Control related**

Function	Address	Set Value	Initial Value	Description
DC Iris Mode	61	0: Open 1: Auto	0	Set to Open when a DC Iris Lens is NOT in use. ※ Note (*3)
DC Iris Response Speed	77	0 (slow)~15 (fast)	8	This is to set the speed of DC Iris response when DC Iris Mode is Auto. The bigger the value, the faster the response speed becomes. When hunting occurs in camera, slower the response speed to adjust it according to the characteristics of DC Iris lens used.

(\*3) When shooting a high luminance object with DC iris function, hunting may occur under some conditions.  
In such cases, please adjust DC Iris Response Speed or Exposure Compensation Value.

**OSD related**

Function	Address	Set Value	Initial Value	Description
OSD Up button	90	0: 1 push 1: continuous push	None	Commands to operate OSD. Send commands every 60ms for continuous push. (Dedicated to SU)
OSD Down button	91	0: 1 push 1: continuous push	None	
OSD Right button	92	0: 1 push 1: continuous push	None	
OSD Left button	93	0: 1 push 1: continuous push	None	
OSD Center button	94	0: 1 push 1: continuous push	None	
Text Color	95	0: Black 1: Blue 2: Red 3: Magenta 4: Green 5: Cyan 6: Yellow 7: White	7	This is to set the text color of OSD menu.
Highlight Color	96	0: Black 1: Blue 2: Red 3: Magenta 4: Green 5: Cyan 6: Yellow 7: White	5	This is to set the selected letter's font color of OSD menu.  If user specifies the same color as the text color, error will occur because the selected letters cannot be recognized.
OSD Off	99	1 (fixed)	None	This is to close OSD menu. (Dedicated to SU)

**Others**

Function	Address	Set Value	Initial Value	Description
Camera Setting Store	100	0~3	0	User can store four kinds of camera settings. Execute SAVE (SU 705 1) to save the registered values into the non-volatile memory. The registered data and address to store are not subject to Init command (SU 700 0).
Camera Setting Load	101	0~3		This is to readout and reflect the registered values set by Camera Setting Store to the camera. Selection of address to store and address to load are common so that this command keeps the last set value with Store or Load.. (GU 100 and GU 101 always return the same value).
LTC Mode	103	0: Off 1: On	0	This is to set OFF/ON of LTC signals insertion.
LTC Reset	104	1: Reset	None	This is to reset internal free-run timer of LTC. (Dedicated to SU)
GenLock V Offset	106	-1024~1023	0	Adjustment of V phase when mode is external sync.
GenLock H Offset	107	-2048~2047	0	Adjustment of H phase when mode is external sync.
H Flip	110	0: Off 1: On	0	This is to set horizontal flip of the output image.
V Flip	111	0: Off 1: On	0	This is to set vertical flip of the output image.
Test Pattern	120	0: Off 1: Cross Line 2: Color Bar	0	This is to set test pattern indication. H Flip and V Flip settings does not affect the test pattern. (Test pattern does not flip).
Cross Line Position	121	The 1 <sup>st</sup> Parameter: X coordinate 0~1919	960	This is to set the address of the crossing point.
		The 2 <sup>nd</sup> Parameter: Y coordinate 0~1079	540	
Init	700	0 (fixed)	None	This is to restore camera settings to factory settings. Camera store data, address to store, defective pixel correction data, and baud rate are not subject to this command. (Dedicated to SU)

**Others (Cont.)**

Function	Address	Set Value	Initial Value	Description
Save	705	1 (fixed)	None	This is to save camera settings. After storing the current camera settings by Store (Equivalent to SU100), this command saves the stored data, the address to store, defective pixels correction data, and baud rate. (Dedicated to SU)
Version Information	721	1: Microcomputer version 2: FPGA version	None	This is to acquire version information. (Dedicated to GU)
Baud Rate	725	9600, 38400, 115200 (bps)	9600	This is to set the speed of serial communication. Refer to <a href="#">Section 5.1.1. Changing Speed of Serial Communication</a> .
SDI Compatibility Mode	750	0: Off 1: On	0	With factory setting (Off), if user selects HLG75 or BT.2020, changes made will be reflected to SDI Payload ID. With SDI compatibility mode ON, however, changes made are not subject to reflect. Set this command ON if you are using a receiving equipment, which outputs no image with HLG75 or BT.2020.

**Defective Pixels Correction**

Function	Address	Set Value	Description
Detection of defective pixels	200	The 1 <sup>st</sup> Parameter: Threshold value: 0 ~ 4095	This is to detect defective pixels (white defect) and register them as user register data. Defective pixels are output value, which exceeds the threshold level. Execute this command with light shielded, and set appropriate gain and shutter values.
		The 2 <sup>nd</sup> Parameter: Registration mode. 0: New registration 1: Additional registration	
Registration of defective pixels	201	The 1 <sup>st</sup> Parameter: X coordinate 0~1919	This is to register defective pixels as user register data by specifying their coordinates.
		The 2 <sup>nd</sup> Parameter: Y coordinate 0~1079	
Deletion of defective pixels	202	The 1 <sup>st</sup> Parameter: X coordinate: 0~1919	This is to delete defective pixels from user register data by specifying their coordinates. (Dedicated to SU)
		The 2 <sup>nd</sup> Parameter: Y coordinate 0~1079	
Deletion of defective pixels correction data	203	1: Entire deletion	Delete all user register Data. (Dedicated to SU)
Indication of defective pixels correction data	204	1: Indicate the coordinates and their attributes of all defective pixels. 2: Indicate the coordinates and their attributes of user register data. 3: Indicate the total number of all registered defective pixels. 4: Indicate the number of user register data.	This is to indicate information on the registered defective pixels correction data. (Dedicated to GU)

- When user specifies "new registration" with defective pixel detection command, the command deletes only user register data registered by defective pixel detection command. The command does not delete data registered by defective pixel registration command.
- The command classifies registered defective pixels into four types. Attribute [W] and [B] are for the data registered at factory, attribute [U] is the data registered by user with defective pixel detection command, and attribute [P] is the data registered by user with defective pixel registration command.
- [GU 200] command shows the number of pixels classified under [U] attribute, and [GU 201] command shows the number of pixels classified under [P] attribute.
- User can change only user-register data, and cannot remove the factory data upon shipment.
- User cannot register the pixels already been registered as factory-data.

## 5.3. Quick Reference Table

## 5.3.1 Quick Reference Table for Gain Settings

	Magnification	dB	GainValue (Magnification×0x10000)	
			DEC	HEX
<b>0</b>	<b>1.000</b>	<b>0.000</b>	<b>65536</b>	<b>00010000</b>
1	1.122	1.003	73561	00011F59
2	1.260	2.007	82570	0001428A
3	1.414	3.010	92681	00016A09
4	1.587	4.014	104031	0001965F
5	1.782	5.017	116771	0001C823
<b>6</b>	<b>2.000</b>	<b>6.021</b>	<b>131072</b>	<b>00020000</b>
7	2.245	7.024	147123	00023EB3
8	2.520	8.027	165140	00028514
9	2.828	9.031	185363	0002D413
10	3.175	10.034	208063	00032CBF
11	3.564	11.038	233543	00039047
<b>12</b>	<b>4.000</b>	<b>12.041</b>	<b>262144</b>	<b>00040000</b>
13	4.490	13.045	294246	00047D66
14	5.040	14.048	330280	00050A28
15	5.657	15.051	370727	0005A827
16	6.350	16.055	416127	0006597F
17	7.127	17.058	467087	0007208F
<b>18</b>	<b>8.000</b>	<b>18.062</b>	<b>524288</b>	<b>00080000</b>
19	8.980	19.065	588493	0008FACD
20	10.079	20.069	660561	000A1451
21	11.314	21.072	741455	000B504F
22	12.699	22.076	832255	000CB2FF
23	14.254	23.079	934175	000E411F
<b>24</b>	<b>16.000</b>	<b>24.082</b>	<b>1048576</b>	<b>00100000</b>
25	17.959	25.086	1176986	0011F59A
26	20.159	26.089	1321122	001428A2
27	22.627	27.093	1482910	0016A09E
28	25.398	28.096	1664510	001965FE
29	28.509	29.100	1868350	001C823E
<b>30</b>	<b>32.000</b>	<b>30.103</b>	<b>2097152</b>	<b>00200000</b>
31	35.919	31.106	2353974	0023EB36
32	40.317	32.110	2642246	00285146
33	45.255	33.113	2965821	002D413D
34	50.797	34.117	3329021	0032CBFD
35	57.018	35.120	3736700	0039047C
<b>36</b>	<b>64.000</b>	<b>36.124</b>	<b>4194304</b>	<b>00400000</b>
37	71.838	37.127	4707947	0047D66B
38	80.635	38.130	5284492	0050A28C
39	90.510	39.134	5931642	005A827A
40	101.594	40.137	6658043	006597FB
41	114.035	41.141	7473400	007208F8
<b>42</b>	<b>128.000</b>	<b>42.144</b>	<b>8388608</b>	<b>00800000</b>
43	143.675	43.148	9415894	008FACD6
44	161.270	44.151	10568984	00A14518
45	181.019	45.154	11863283	00B504F3
46	203.187	46.158	13316085	00CB2FF5
47	228.070	47.161	14946800	00E411F0
48	251.189	48.000	16461899	00FB304B

## 5.3.2 Quick Reference Table for Shutter Settings

Exposure Time [s]	ShutValue (Exposure time [s]×0x100000)	
	DEC	HEX
1/23.98	43734	0000AAD6
1/24	43691	0000AAAB
1/25	41943	0000A3D7
1/29.97	34987	000088AB
1/30	34953	00008889
1/50	20972	000051EC
1/59.94	17494	00004456
1/60	17476	00004444
1/90	11651	00002D83
1/100	10486	000028F6
1/125	8389	000020C5
1/180	5825	000016C1
1/250	4194	00001062
1/350	2996	00000BB4
1/500	2097	00000831
1/725	1446	000005A6
1/1000	1049	00000419
1/1500	699	000002BB
1/2000	524	0000020C
1/3000	350	0000015E
1/4000	262	00000106
1/6000	175	000000AF
1/8000	131	00000083
1/9600	109	0000006D
1/11200	94	0000005E
1/13600	77	0000004D

## 6. How to Operate the Camera with OSD Function

In addition to operation by serial communication explained earlier, you can operate the camera with OSD menu on a monitor screen by connecting an optional remote controller (RU-100).

### 6.1. How to Operate OSD Menu by Remote Controller

[CENTER]	To indicate OSD top menu on your monitor screen when OSD menu does not appear. Also use this button to choose the selected menu.
[▲]	Move up.
[▼]	Move down.
[◀]	Change options.
[▶]	Change options.

### 6.2. Indication of OSD Menu

- Menu with ▼ at the line end indicates that there are submenus to open with CENTER button.
- Menu with ◀ at the line end indicates that there is an upper hierarchical menu to return with CENTER button.
- Menu with ▶ at the line head indicates that CENTER button can execute command for the chosen item. Other menus execute commands every time user changes selection with [◀] [▶].
- Please note that only representative values are selectable for gain and shutter with OSD menu. If you wish to set specific values, please use serial command setting.
- Some hidden items are mode-dependent. For example, when gain mode is Auto, menu does not indicate gain value.



### 6.3. OSD Menu Hierarchical Structure

Hierarchical structure of OSD menu is as below. (Exclusion; Items to move hierarchies)

- └ Output Format
  - | └ Video Format
- └ Gain/Shutter/Iris
  - | └ Gain Mode
  - | └ Gain Value
  - | └ Gain Max Value
  - | └ Shutter Mode
  - | └ Shutter Value
  - | └ Shutter Limit
  - | └ Iris Mode
  - | └ Iris Speed
  - | └ AE Speed
  - | └ Exp Comp Value
  - | └ Metering Mode
  - | └ Spot Block
  - | └ Flicker Cancel
- └ White Balance
  - | └ WB Mode
  - | └ Auto Func
  - | └ Preset Func
  - | └ Preset Temp
  - | └ Manual Memory
  - | └ Manual Red Gain
  - | └ Manual Blue Gain
  - | └ One Push WB
  - | └ LB Shift
  - | └ CC Shift
- └ Image Control
  - | └ Red Balance
  - | └ Green Balance
  - | └ Blue Balance
  - | └ Master Pedestal
  - | └ Red Pedestal
  - | └ Green Pedestal
  - | └ Blue Pedestal
  - | └ Detail
  - | └ Gamma
  - | └ Knee
  - | └ D-Range
  - | └ Noise Reduction
  - | └ Color Correction
  - | └ Color Saturation
  - | └ Color Suppression
  - | └ Cyan Suppression
  - | └ Color Space
  - | └ Color Adjustment
    - | └ Magenta (Hue/Saturation/Depth)
    - | └ Red (Hue/Saturation/Depth)

- | | └ Yellow (Hue/Saturation/Depth)
- | | └ Green (Hue/Saturation/Depth)
- | | └ Cyan (Hue/Saturation/Depth)
- | | └ Blue (Hue/Saturation/Depth)
- | └ SDI Compatibility
- └ Flip
  - | └ Horizontal Flip
  - | └ Vertical Flip
- └ LTC
  - | └ LTC Mode
  - | └ LTC Reset
- └ GenLock
  - | └ V Offset
  - | └ H Offset
- └ Test Pattern
  - | └ Test Pattern
  - | └ Position X
  - | └ Position Y
- └ OSD Color
  - | └ OSD Color (Text/Highlight)
  - | └ Default
- └ Save/Load/Init
  - └ Save Settings
  - └ Load Settings
  - └ Init Settings

PRELIMINARY

7. Dimensions

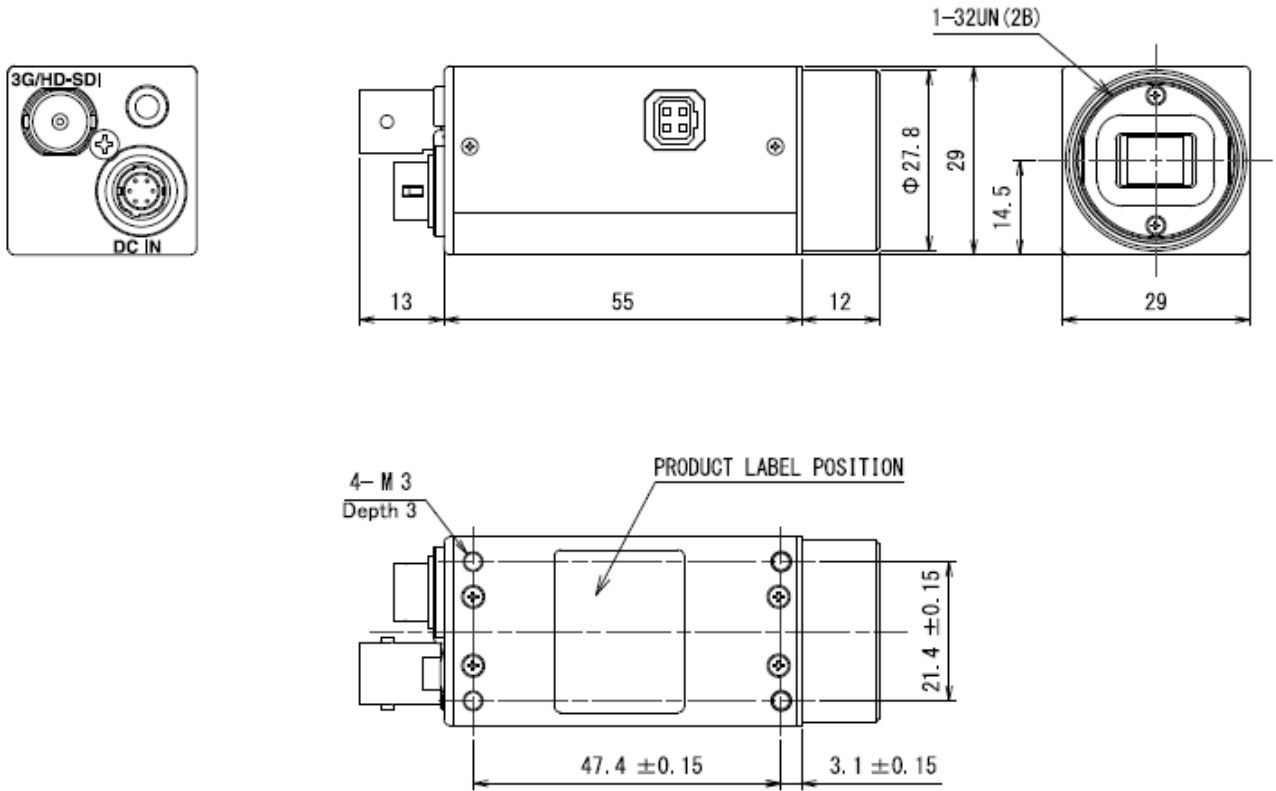

PRELIMINARY

## 8. Case for Indemnity (Limited Warranty)

### 8.1. Product Warranty

The term of warranty of this product is within 1.5 years from the date of shipping out from our factory. If you use the product properly and discover a defect during the warranty period, and if that was caused by designing or manufacturing, CIS Corporation, at its option, repairs or replaces it at no charge to you. Products out of warranty period will be subject to charge.

CIS should not hold responsible for damages or losses if;

- damages or losses are caused by earthquake, lightning strike, fire, flood or other acts of God.
- damages or losses are caused by deliberate or accidental misuse by the user, or failure to observe the information contained in the instructions in this Product Specification and Operational Manual.
- damages or losses are caused by repair or modification conducted by the customer or any unauthorized party.

### 8.2. CMOS Defective Pixels

CIS applies defective pixel correction prior to the shipment of the product. However, the number of defective pixels are subject to increase due primarily to the effect of cosmic rays. Due to this nature, CIS should not hold responsible for the natural increase of defective pixels.

### 8.3. Product Support

Should you have any problems with the product, and if you need our further analysis and/or repair, please contact your local distributor.