



P/N : 388085110
PRINTED IN KOREA

Distributed by

USER'S MANUAL

INTEGRATED CONTROLLER WTX-1200A

WTX-1200A



Please read the instructions carefully and keep this manual for future reference.

CONTENTS

USE PRECAUTIONS	3p
1.WARNING	
2.CAUTION	
3.MAINTENANCE	
MAIN FUNCTIONS AND FEATURES.....	4p
1.Summary	
2.Feature	
3.Controller Button Overview	
CONTENTS AND BATTERY CHANGE	5p
1.Products	
2.Battery Change	
HARDWARE OVERVIEW.....	6p
PART NAME & FUNCTION	7p
CONNECTION	8p
RS-485/422 connection	
DVR connection	
WTX-1200A and DVR mouse function use	
SYSTEM CONFIGURATION.....	9p
PTZ Control	11p
1.Power On	
2.LCD display	
3.Camera ID Set Up	
CONTROLLER CONTROL / SET UP	13p
PTZ SET UP.....	14p
JOYSTICK CALIBRATION	15p
BASIC FUNCTION SETTING AND CONTROL.....	16p
1.Preset	
2.Tour	
3.Pattern	
4.Scan	
5.Auto Pan	
WTX-1200A PROTOCOL	18p
SPECIFICATION	20p
DRAWING.....	21p

USE PRECAUTIONS

To prevent risk or damage on the property must keep the following information please.



*Please note the "Warning" and "Caution".
"Warning" and "Caution" mean as follows.



Warning: Violation of the instructions may cause death or injury.

Caution: Violation of the instructions may cause personal injury or property damage.



WARNING

- Before using this product, please be sure to read the user manual.
 - Install this product in the stable and right place.
 - Do not place conductive material (such as screw driver, coin, iron...etc.)nor vessel full of water.
 - Use the indicated power only.(DC 12V).
 - Do not use this product where flammable substances are used.
 - Do not touch electrical parts with wet hands.
 - Products used to be a problem, please discontinue.
 - When this product is not normally operated, contact seller or service center.
 - Never disassemble the equipment.
- (Problems caused by user's disassembly are not responsible.)



CAUTION

This device is recommended for indoor use only.

- Outdoor/Place exposed to rain or moisture should not be used.
 - Drop in water may cause severe damage.
 - Do not use in too heavy dust, smoke nor humid environments.
 - The device do not leave too hot or cold.
 - Always keep the operating temperature between 0°C and 45°C.
 - Do not put this unit in direct sunlight.
 - (It causes discolor or damage.)
 - Do not give this unit a severe shock.
 - Unplug the power when thunder, lightning storm.
- (May cause fire or damage.)

MAINTENANCE

- When controller body dirt, turn off the power and wipe the surface with a soft cloth.
- Alcohol, benzene and other chemicals to prevent contact. (The surface is changeable)

== MAIN FUNCTIONS AND FEATURES

1. Summary

This product is system integrated controller which can control up to 255 units such as speed dome, DVR, multiplexer, receiver...etc.

Excellent system compatibility with a variety of protocol implementations.

An array of buttons, user convenience easy connection with other products and fine control make this unit as market needful product. This CCTV dedicated controller is very convenient to use by anyone.

2. Features

- Elegant and ergonomic design
- One unit can control up to 255 pan/tilt cameras and other equipments.
- Long distance remote control is possible through RS-485/422 communication.
- Low power consumption design (20mA.LED off)
- Joystick pan/tilt speed controlling is possible.
- Menu control, company logo input are possible by adopting LCD window.
- Easy to control preset, tour, scan, pattern by using function key.
- The administrator's password can be set.
- Easy connection with DVR and other devices(Interface).
(Protocol modifications are required)
- Mobile using is possible by using inner 9V battery.
- S/W Update port(Protocol update).
- USB Mouse function(DVR control)
- Easy to set-ended by built in signal splitter function.(3ch.Max)

3. Controller button overview

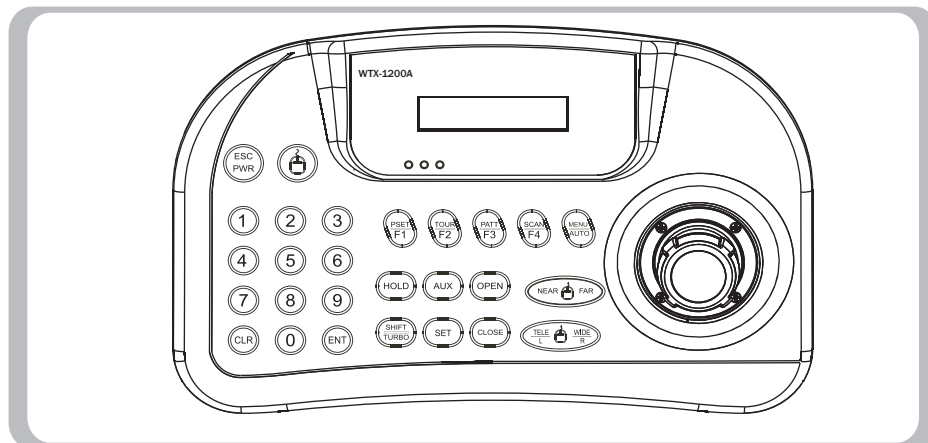

== CONTENTS AND BATTERY CHANGE

1. Products

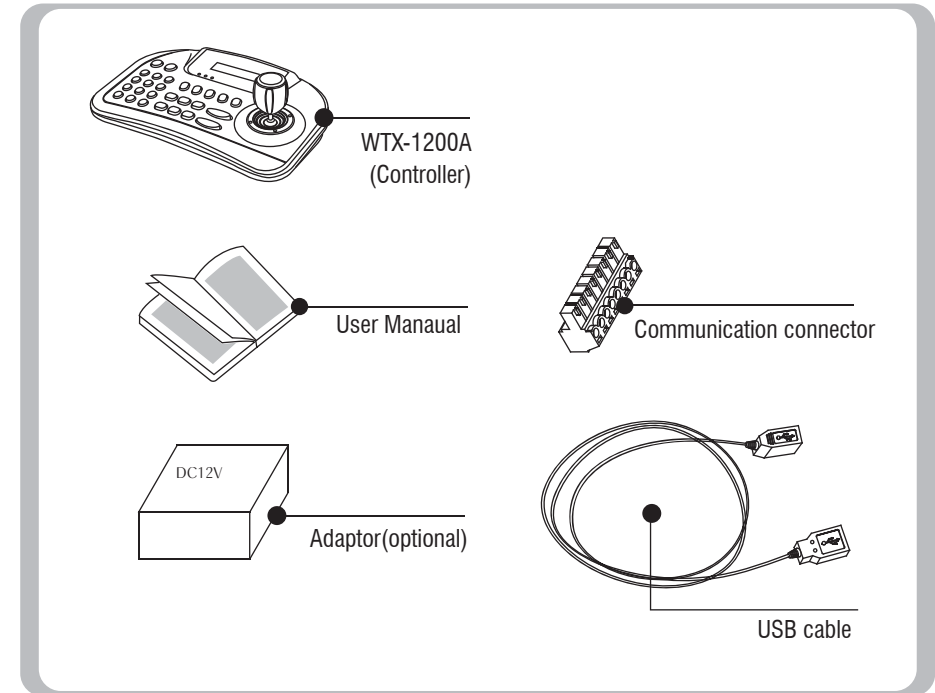

2. Battery change

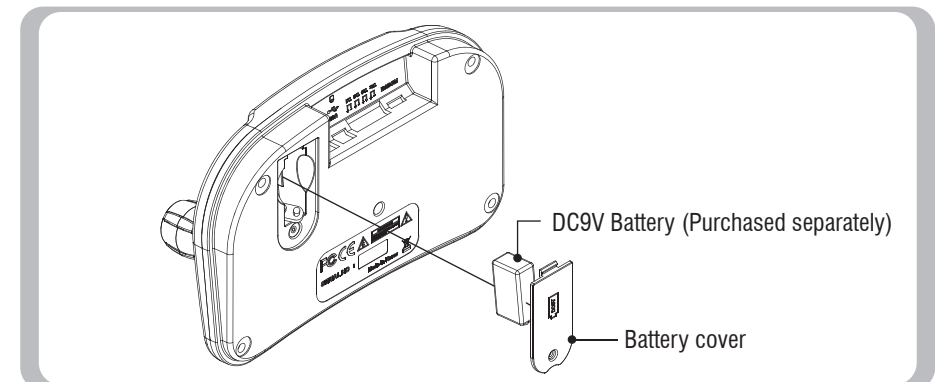

Hardware Overview

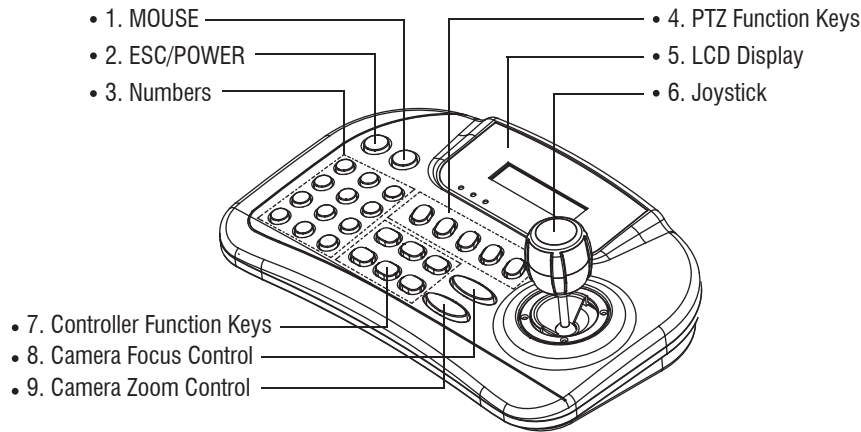

NO.	Button	Function
1	MOUSE 	Mouse function ON/OFF button
2	ESC/POWER 	Power on and clear the entered value, or Pre-move is used.
3	Numbers 	Enter the numbers or Set up camera ID/PTZ.
4	Function keys 	F1 ~ MENU/AUTO : Control various functions (preset, tour, pattern, scan, auto) of controlled devices. MENU : Adjust PTZ menu.
5	LCD DISPLAY 16 x 2 Graphic display 	Shows the number entered, system state and running features.
6	Joystick 	PTZ's up, down, left, right position control and MENU settings.
7	Controller Function keys 	HOLD :: System features pause. SHIFT/TURBO : When you press the joystick and button at the same time, the camera helps you to make quick moves. Optional (special functions, custom functions) functions are used in. AUX : External inputs are used in. SET :: Adjust camera (pan/tilt)'s menu. OPEN: IRIS open, CLOSE : IRIS close
8		Adjust Zoom camera's focus. (Manual mode).
9		Activate Zoom camera's Wide/Tele function.

Part Name & Function

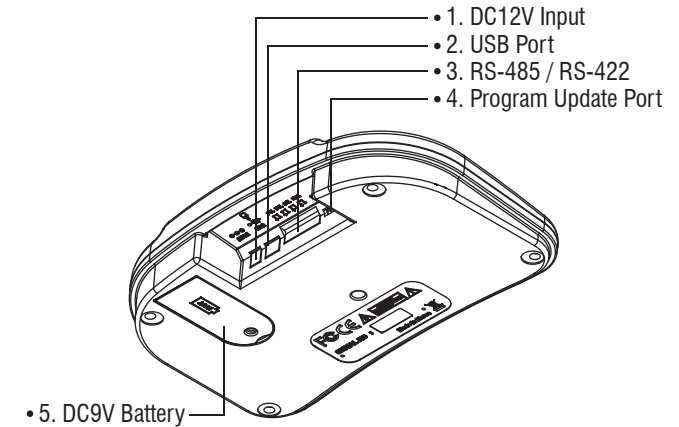

No.	Item	Function
1	 DC 12V Input	Power input (DC 12V, 140mA)
2	 USB PORT	USB connecting terminal
3	 TRx Tx3 Tx2 Tx1 RS-485 / RS-422	Use Tx1,2 or 3 for RS-485 /RS-422 connection
4	Program Update Port	Program update port
5	 DC9V Battery	DC9V battery part

Mouse Function

To use mouse function, USB driver should be installed in advance.

No.	Item	Mouse Function
1		Push a mouse button for 2~3 seconds
2	Discription	Mouse character description will be displayed
3	Reference Key button 	= Left button of Computer mouse = Right button of Computer mouse = Scroll key of Computer mouse (Middle Key) (Simultaneously near far key push and joystick move)
4	DVR Connection method	Push a mouse button shortly.
5	Discription	↔

CONNECTION

INTEGRATED Controller WTX-1200A Keyboard

can be used to connect&control DVR, MULTIPLEXER and other external devices.

RS-485/422 Connection

External device's RS-485/422 port is connected to this Keyboard's RS-485/422 terminal block.

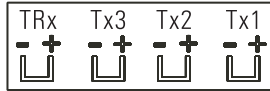

When RS-485/422 connection, be careful +, - polarity not be changed. And check device's RS-485/422 support is available or not.

DVR Connection

Connect USB cable of this equipment to DVR.

Press the top of the controller's button.

If you briefly press : Camera control mode is switched on the keyboard.

If you press and hold : Mouse function is activated through USB Port.

If you briefly press, displays are as follows:.

DVR WKRY 9.6
ID : 001

Transfer speed is 9600bps, Control ID is 001.
Display ID is DVR ID.

If you want to control other ID DVR, push number key and ENT then ID will be changed.
(EX. No.3 button + press for 3 seconds)

* Constant value for each button, for each communication (COMMAND) has been set.

WTX-1200A and DVR mouse function use.

DVR WKRY 9.6
ID : 001 MOUSE

Press and hold the mouse button to start the feature.
 Mouse function will start as phrase(MOUSE) flashing on the screen.

- 1.DVR must be PC compatible.(Device driver required)
- 2.DVR Power ON
- 3.WTX-1200A Power ON
- 4.Mouse speed setting in the main setup (WTX-1200A 2 +)
- 5.WTX-1200A and DVR connected.
6. If you press and hold button, you can see phrase(MOUSE) flashing on the screen.
7. Check the mouse pointer on the screen.
8. Mouse function used as joystick control.

USE 'L', 'R' button of mouse

Use mouse-pointer moving

SYSTEM CONFIGURATION

Single system configuration (Camera 1, kyeboard 1, DVR 1)

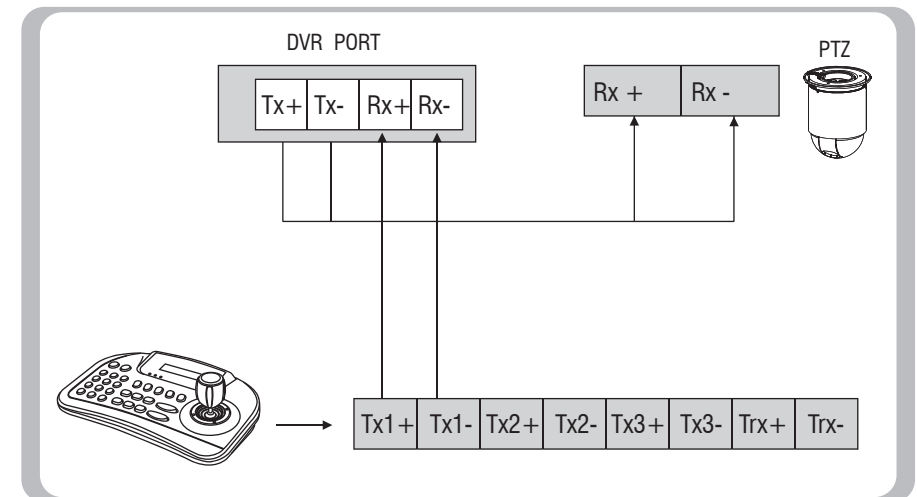
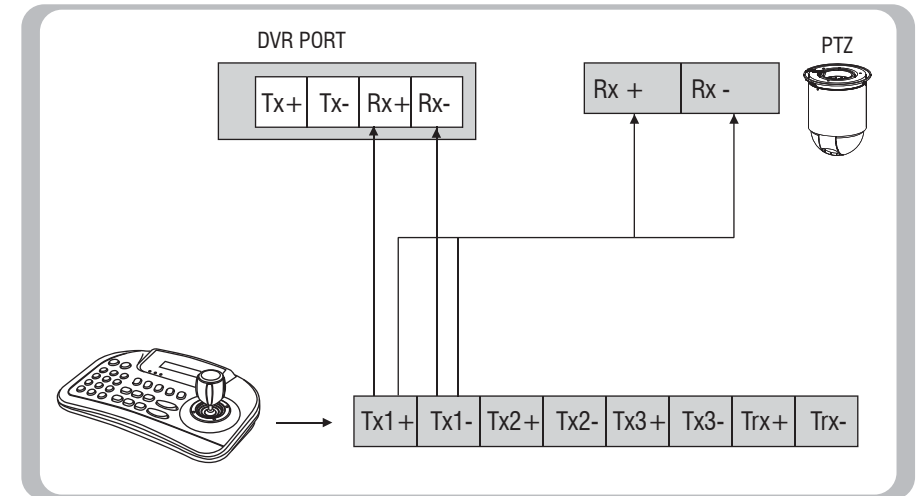

SYSTEM CONFIGURATION

Single system configuration (PTZ connected directly)

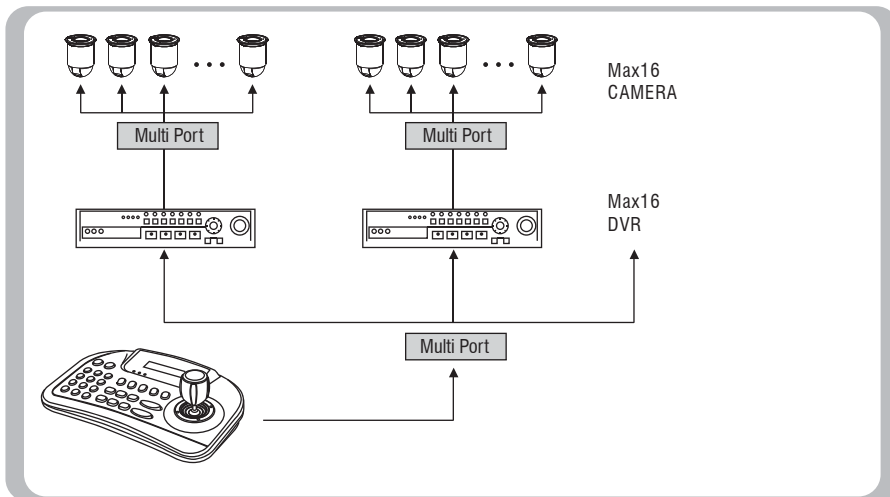

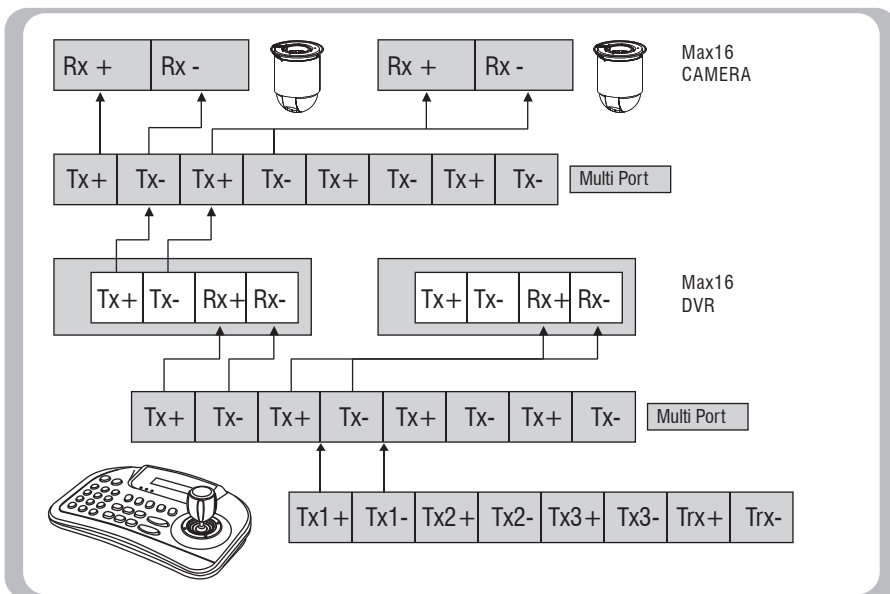

Multi system configuration



PTZ CONTROL

1. Power On

This device has two types of power use.

- 1) Connect provided adaptor to power.
- 2) Insert 9V batteries inside. (Do not connect adaptor.)
- 3) Power on external devices which are connected to this device before power on of this device.
- 4) Turn on the power by pressing  button.
- 5)  will be displayed on the screen.

2. Start page displayed

- 1. ID: Shows the ID of the currently selected camera.

- 2. Shows the currently selected protocol. 

3. Camera ID Set up

- 1. Input wanted number button in the number pad.

- 2. Press  button then Camera ID will be set up as your selected number.



* 1-255 numbers are selectable. When the number outside the range of inputs selected, last selected numbers will be treated as the first digit.

CONTROLLER CONTROL/SETUP

Instructions and Setting up the MAIN SETUP

Connect the power adapter into the back of the keyboard and pressing  button, The following display appears on the LCD screen.

Main MENU Set up

If you press button 2 +  for 2~3 seconds, you can enter into the MAIN SETUP.

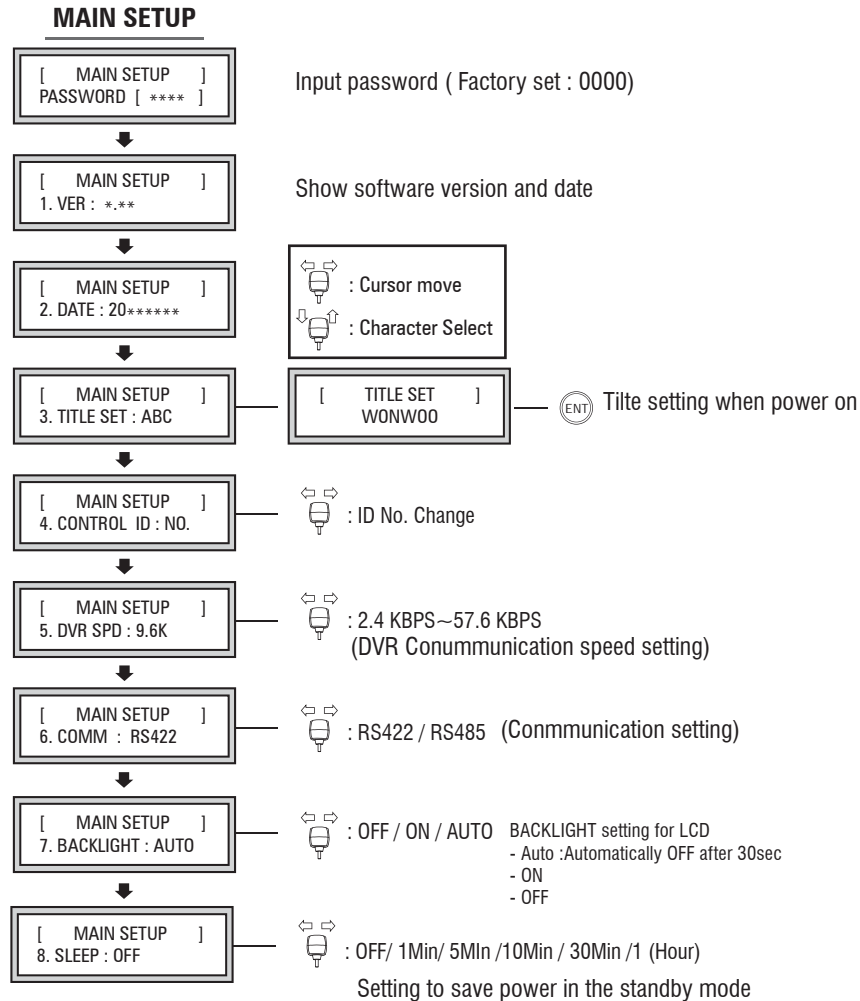

CONTROLLER CONTROL/SETUP

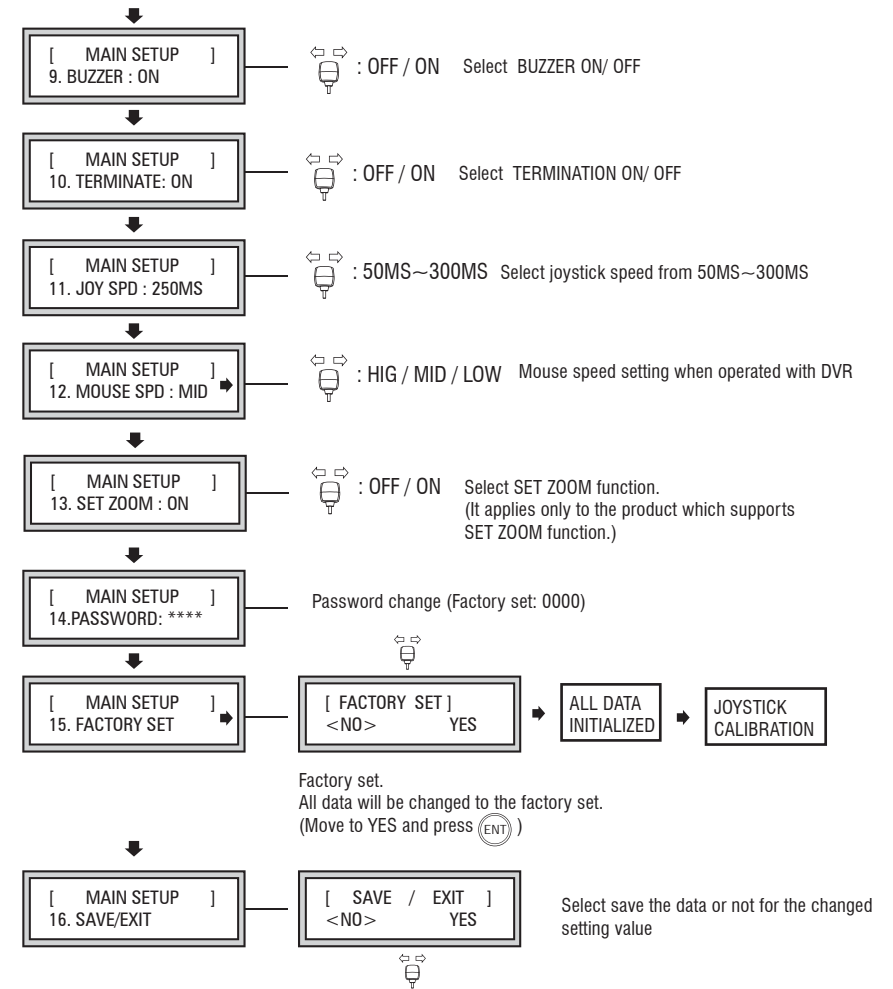

After factory set, the Tx LED on the LCD screen flashing is not a malfunction.
 After factory set, the joystick must reset the settings in the Joystick Calibration mode.

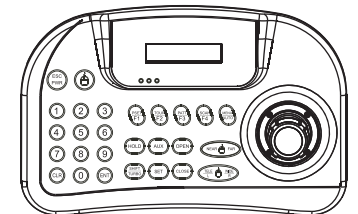

PTZ SETUP

PTZ SETUP

If you press button 1 +  for 2~3 seconds, you can enter into the PTZ SETUP menu.

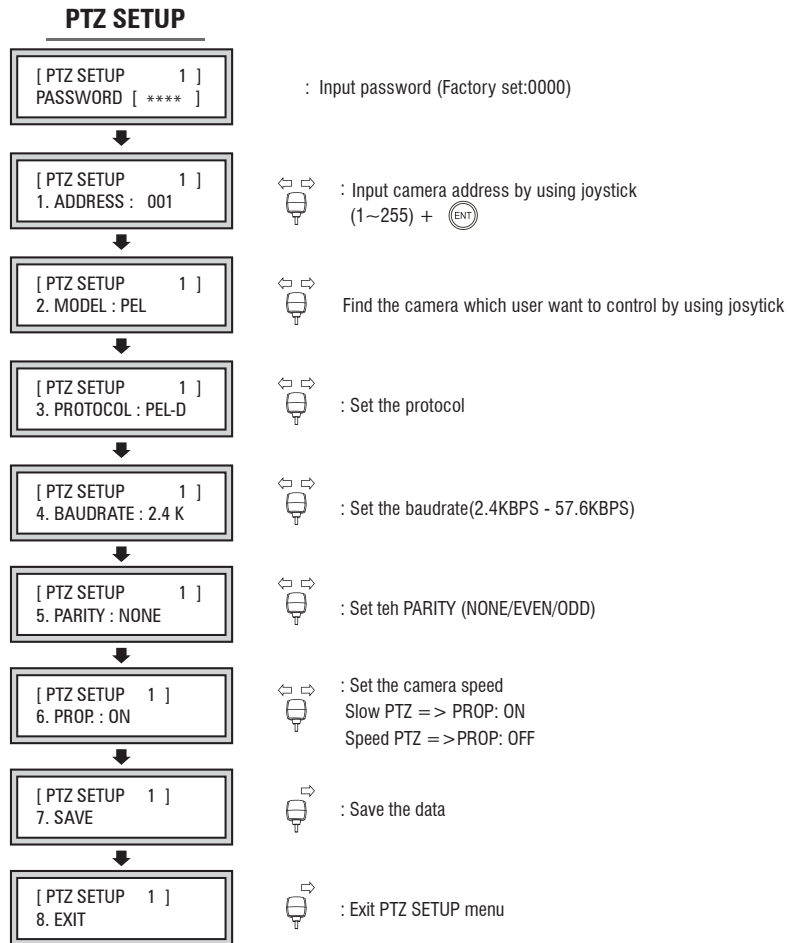

JOYSTICK CALIBRATION

It is for the keyboard to set the Max.movement of joystick

If you press button 3 +  for 2~3 seconds, you can enter into the JOYSTICK CALIBRATION menu.

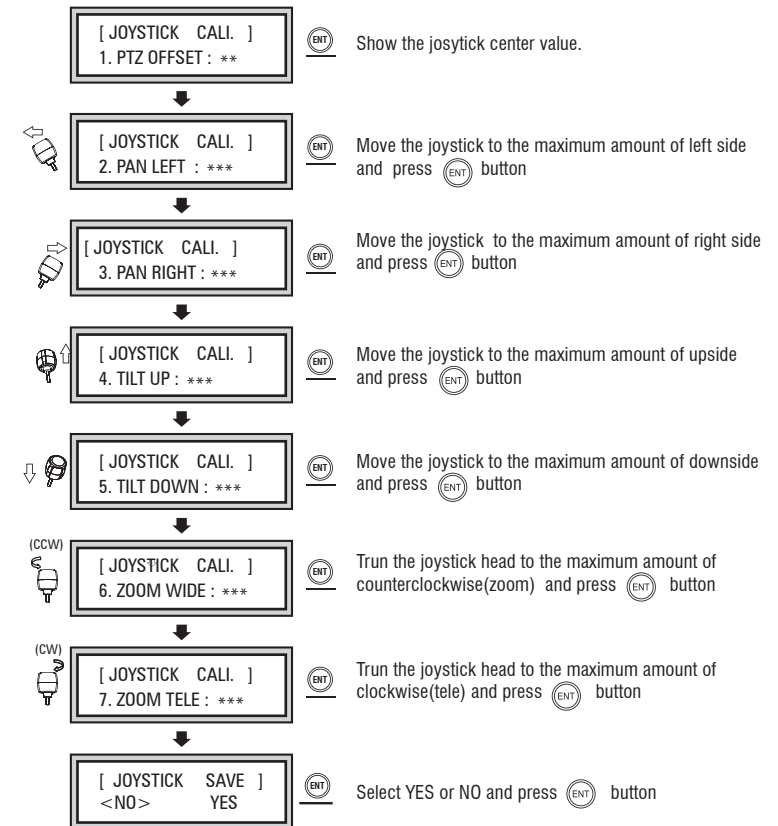

:: BASIC FUNCTION SETTING AND CONTROL

1. PRESET

User can set the camera position where user want to see.

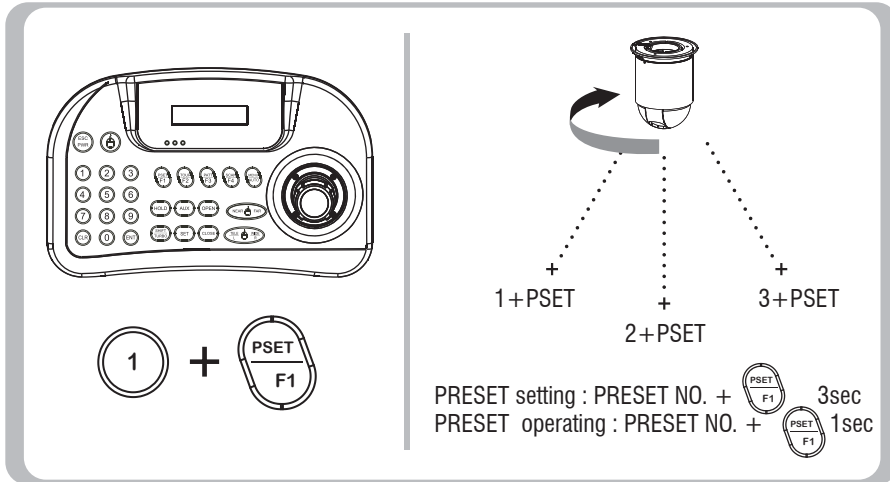

2. TOUR

When Tour function runs, camera moves from the preset assigned as the 1st point to the preset assigned as the last point in sequence. The camera will stay to the each point for the time set to the dwell time in Tour Edit and move to the next point.

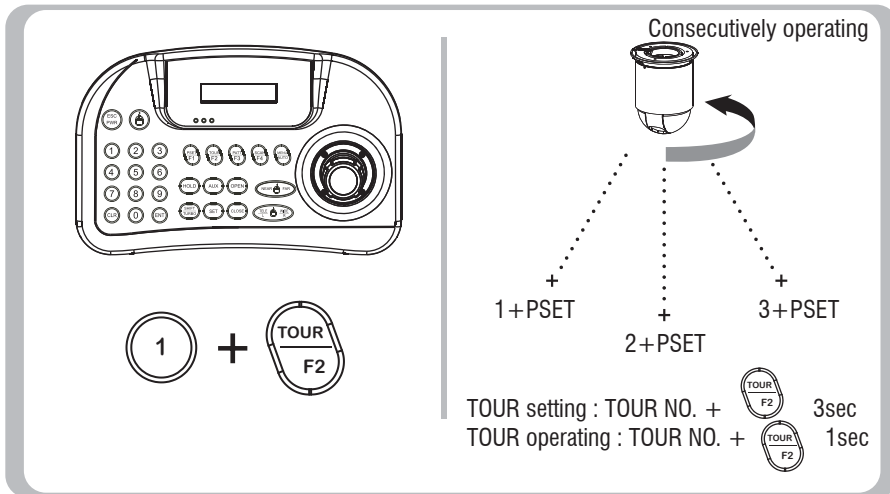

:: BASIC FUNCTION SETTING AND CONTROL

3. PATTERN

Camera memorizes the path (mostly curve path) by joystick of controller for assigned time and revives the path exactly as it memorized.

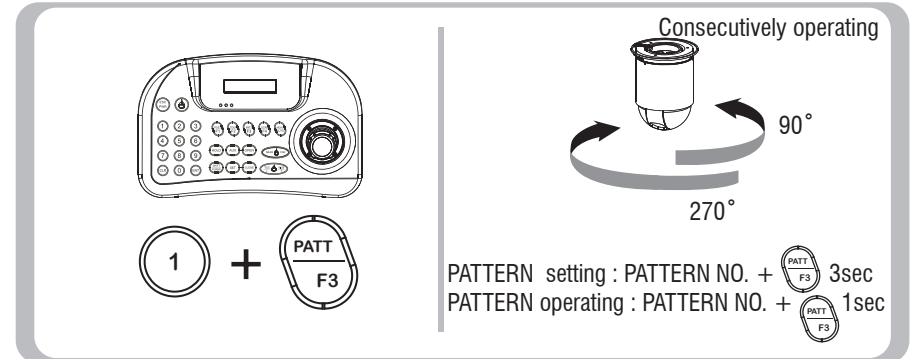

4. SCAN

Camera moves between 2 positions if there is no PTZ command after passing the assigned Dwell time.

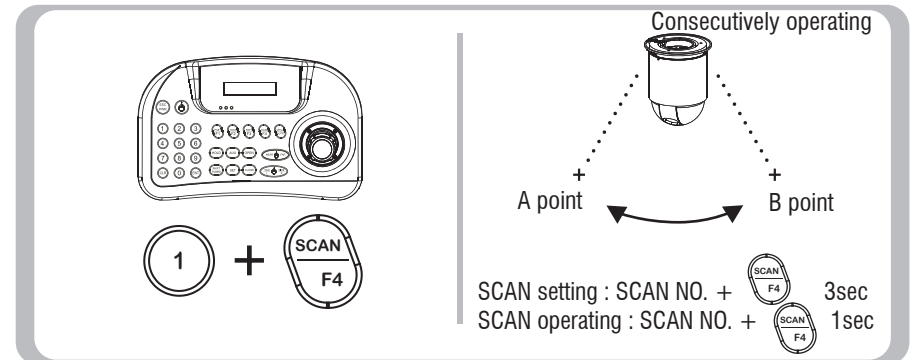

5. AUTO PAN

Camera moves two preset pan positions repeatedly.

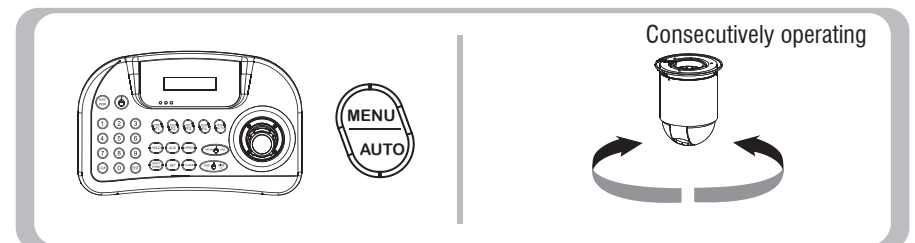

WTX-1200A PROTOCOL

1. Serial Communication Format

Data Communication : RS485 / RS-422

Data bit : 8bit

Stop bit : 1bit

Parity bit : None

Transmission speed : 2400, 4800, 9600, 19200, 38400, 57600 bps

2. DATA Format(binary 5bytes)

STX : 0xA0

ETX : 0xAF

ADDR : 0x01 ~ 0xFF(Address Change : addr value + ENT + long)

byte 1	byte 2	byte 3	byte 4	byte 5
STX	ADDR	CMD	DATA	ETX

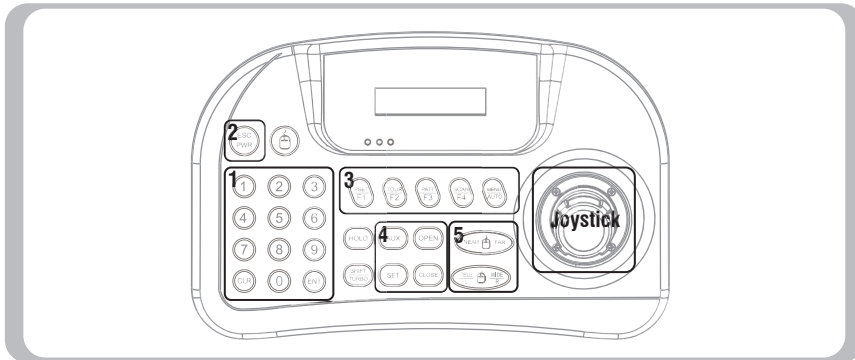

Joystick

CMD		DATA						
Action	Value	Action	Value	Action	Value			
Wide	0x87	Left	0x7n	Up	0xn7			
	0x86		0x6n		0xn6			
	0x85		0x5n		0xn5			
	0x84		0x4n		0xn4			
	0x83		0x3n		0xn3			
	0x82		0x2n		0xn2			
	0x81		0x1n		0xn1			
Stop	0x80	Stop	0x0n	Stop	0xn0			
	0x88		0x9n		0xn9			
	0x89		0xAn		0xnA			
	0x8A		0xBn		0xnB			
	0x8B		0xCn		0xnC			
	0x8C		0xDn		0xnD			
	0x8D		0xEn		0xnE			
	Tele		0x8F		Right	0xFn	Down	0xnF

**n = don't care

WTX-1200A PROTOCOL

1		CMD	DATA
1	short	0x01	0x01
	shift + short		0x03
2	short	0x02	0x01
	shift + short		0x03
3	short	0x03	0x01
	shift + short		0x03
4	short	0x04	0x01
	shift + short		0x03
5	short	0x05	0x01
	shift + short		0x03
6	short	0x06	0x01
	shift + short		0x03
7	short	0x07	0x01
	shift + short		0x03
8	short	0x08	0x01
	shift + short		0x03
9	short	0x09	0x01
	shift + short		0x03
0	short	0x0A	0x01
	shift + short		0x03
ENT	short	0x20	0x01
	long		0x02
CLR	short	0x21	0x01
	long		0x02
	shift + short		0x03

2		CMD	DATA
ESC	short	0x2A	0x01

3		CMD	DATA
F1	short	0x11	0x01
	long		0x02
	shift + short		0x03
F2	short	0x12	0x01
	long		0x02
	shift + short		0x03
F3	short	0x13	0x01
	long		0x02
	shift + short		0x03
F4	short	0x14	0x01
	long		0x02
	shift + short		0x03
AUTO	short	0x15	0x01
	long		0x02
	shift + short		0x03

4		CMD	DATA
AUX	short	0x22	0x01
	long		0x02
	shift + short		0x03
OPEN	short	0x23	0x01
	long		0x02
	shift + short		0x03
CLOSE	short	0x24	0x01
	long		0x02
	shift + short		0x03
SET	short	0x29	0x01
	long		0x02
	shift + short		0x03

5		CMD	DATA
NEAR	short	0x25	0x01
	long		0x02
	shift + short		0x03
FAR	short	0x26	0x01
	long		0x02
	shift + short		0x03
TELE	short	0x27	0x01
	long		0x02
	shift + short		0x03
WIDE	short	0x28	0x01
	long		0x02
	shift + short		0x03

== SPECIFICATION

MODEL	WTX-1200A
Keyboard communication	Pan/Tilt interface : RS-485/422
	Interface : RS-485/422
	Pan/Tilt operating distance : 4700FT (1029m) on 24 AWG wire
	Protocol : Multiple (Pelco-D, Pelco-P, WONWOO, Etc.) (Baud rate selectable)
Connector Type Data	TERMINAL BLOCK(8p)
Keyboard button	Rubber button
	Numeric keypad and camera function key
Joystick	Stick 3-axis, variable speed with zoom
power	12V DC or 9V battery (batter mode)
Power consumption	Max.140mA
LCD Display	Graphic display 16 character x2 lines
Operating Temp./ Humidity	0℃ ~ 45℃ / 10% ~ 70% Non-condensing
Size, Weight	280(W) x 180(D) x 100(H) / Net : 0.74kg, Gross : 1.28kg

** The design and specification are subject to improvement changes without prior notice.

== DRAWING

